



LOCKSTP®

EXCELLENT GLUELESS SYSTEM

Glueless System Patent-protected worldwide

INTELLIGENT PERFORMANCE

# INTELLIGENT PERFORMANCE

100% Made in Spain

SYSTEM &  
STRUCTURE

---

BENEFITS

---

SIZES

---

COLORS

---

FINISHES

---

MOUNTING  
SCHEMES

---

ACCESSORIES

---

INSTALLATION &  
MAINTENANCE

---

TECH. FEATURES  
& PACKING

LOCKSTEP®  
EXCELLENT GLUELESS SYSTEM

Patent-protected  
worldwide





Wood is a surprising material thanks to its colors, textures, and nuances, with all the benefits of a fully natural material, which must be protected. STP is pursuing an eco-sustainable policy, limiting waste and supporting the renewal of resources.

La madera es un material sorprendente por sus colores, texturas y matices, con todos los beneficios de un material completamente natural, que queremos proteger. STP lleva a cabo una política de sostenibilidad ecológica que limita el desperdicio y apoya la renovación de recursos.

Il legno è un materiale sorprendente per i suoi colori, le sue sfumature e le sue trame, con tutti i benefici di un elemento completamente naturale che vogliamo proteggere. STP porta avanti una concreta politica eco-sostenibile, che limita gli sprechi e sostiene il rinnovamento delle risorse.

由于其颜色、纹理和细微差别，木材是一种令人惊讶的材料，具有完全天然材料的所有好处，必须加以保护。STP正在推行切实的生态可持续政策，限制浪费和支持资源再生。

## WOOD & MORE

A special meeting. Un encuentro especial. Un incontro speciale. 一场特别的奇遇

# LOCKSTP<sup>®</sup>

EXCELLENT GLUELESS SYSTEM

Glueless System Patent-protected worldwide

## INDEX

INDEX / INDICE / INDICE / 索引

p. 4	SYSTEM
p. 5	STRUCTURE
p. 9	BENEFITS
p. 10	SIZES
p. 16	COLORS
p. 18	FINISHES
p. 20	MOUNTING SCHEMES
p. 54	ACCESSORIES
p. 56	STP SILENT UNDERLAY
p. 57	EUROPOSA
p. 58	INSTALLATION PROCEDURES
p. 62	MAINTENANCE INSTRUCTIONS
p. 63	ENVIRONMENTAL CERTIFICATIONS
p. 64	TECHNICAL FEATURES
p. 65	PACKING



CERTIFICATION FSC®, which identifies the products containing wood originated from forests which are managed in a correct and responsible way according to rigorous environmental, social and economical standards. The originating forest is controlled and valued independently according to these standards (principles and rules for a good forest management) which are established and approved by the Forest Stewardship Council a.c. with the participation and the consent of the involved parts.FSC under request.

**nwfa**  
National Wood  
Flooring Association  
MEMBER

The mark of  
responsible forestry

100% Made in Spain

# SYSTEM

SYSTEM / SISTEMA / SISTEMA / 系统

# LOCKSTP<sup>®</sup>

EXCELLENT GLUELESS SYSTEM

Patent-protected  
worldwide



LockSTP is a world-wide patented system, based on alternating tongues and grooves in a modular size of 290 mm which, together with the precise interlocking rings, provide a perfect bond without the use of adhesives. An innovative glueless flooring system that allows unlimited and flexible unique designs every time.

LockSTP es un sistema patentado a nivel mundial, basado en un machihembrado alterno con un tamaño modular de 290 mm que, junto con las anillas de anclaje y su precisión, proporcionan una unión perfecta sin el uso de adhesivos. Un innovador sistema de suelo flotante que permite diseños únicos e ilimitados en todo momento.

LockSTP è un sistema brevettato a livello mondiale, basato sull'alternanza di maschio e femmina in una dimensione modulare di 290 mm che, insieme ai precisi anelli ad incastro, forniscono una perfetta unione senza l'uso di adesivi. Un sistema innovativo di pavimentazione glueless che consente ogni volta design unici, illimitati e flessibili.

LockSTP是一种具有全球专利的安装系统，其模块化尺寸为290毫米，采用交错舌口和凹槽，加上精确的环型锁扣，无需使用粘合剂（胶水），即可实现完美的无胶安装。创新的无胶地板安装系统，让每一次地板安装都能满足无限灵活的独特设计。

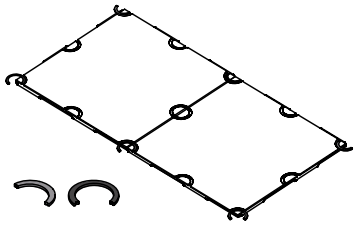

Modular system.  
Sistema modular.  
Sistema modulare.  
模块化系统



Union rings for joint pieces.  
Anillas para la unión de piezas.  
Anelli per unione dei pezzi.  
用于连接部件的环型锁扣



Covering hooks, for glueless wall applications.  
Clips de revestimiento, para fijaciones en seco en pared.  
Clips da rivestimento, per applicazioni a parete senza colla.  
覆盖挂钩，用于墙面的无胶应用

# STRUCTURE

ESTRUCTURA / STRUTTURA / 结构

**WOOD<sup>+</sup>**  
MORE THAN WOOD

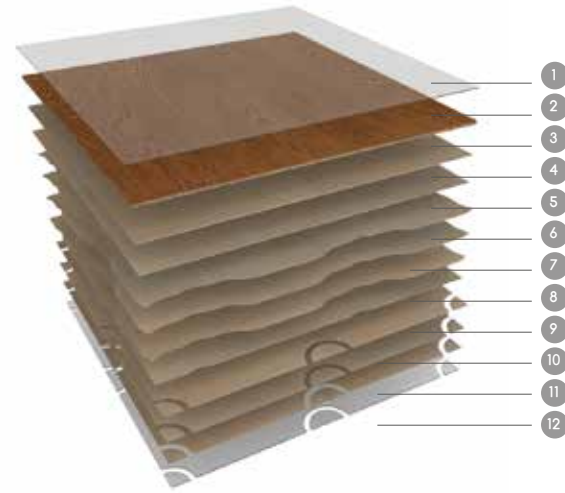

## ENG

- 1 1st overlay STP Classic. High-performance protective overlay consisting of up to 12 coats combining stained, primer, and protective varnish, to give the product a resistant finish and create an oil effect at the same time.
- 2 1st layer. Noble wood of 3/4 mm thickness (depending on collection and finish), micro-beveled on all four sides.
- 3 (3-11) Central Layer. Composed of 9 alternating layers of 100% birch plywood that works as an internal shaft and gives to the whole structure greater strength and stability (Thickness 12mm / 0.47”).
- 4 2nd overlay. Waterproofing varnish. Made of a layer of pore-filler varnish which helps to ensure the compact plan configuration of the piece.

## ESP

- 1 1a aplicación STP Classic. Capa protectora de alto rendimiento compuesta por hasta 12 aplicaciones que combinan tinte, imprimación y barniz protector, para dar al producto un acabado resistente y crear al mismo tiempo un efecto aceite.
- 2 1a capa. Madera noble de 3/4 mm de espesor (según colección y acabado), micro-biselada en los cuatro lados.
- 3 (3-11) Capa central. Compuesta por 9 capas alternas de contrachapado 100% abedul que funciona como eje interno y le da a toda la estructura una mayor resistencia y estabilidad (Espesor 12mm / 0.47”).
- 4 2a aplicación. Barniz impermeabilizante. Compuesto por una capa de barniz tapa poros que contribuye a garantizar la planimetría de la pieza.

## IT

- 1 1a applicazione STP Classic. Pellicola protettiva ad alte prestazioni composta da un massimo di 12 mani che combinano vernice per la colorazione, primer e vernice protettiva, per conferire al prodotto una finitura resistente e creare allo stesso tempo un effetto olio.
- 2 1o strato. Legno nobile di 3/4 mm spessore (a seconda della collezione e della finitura), micro-biselato sui quattro lati.
- 3 (3-11) Strato centrale. Composto da 9 strati alternati di multistrato di betulla 100% che hanno la funzione controbilanciante e conferisce a tutta la struttura maggiore resistenza e stabilità (Spessore 12mm / 0.47”).
- 4 2a applicazione. Vernice impermeabilizzante. Costituita da un strato di vernice per la chiusura dei pori che contribuisce a garantire la planarità del materiale.

## CN

- 1 经典保护层：由多达12层的着色、底漆和保护清漆组成的高性能保护层，给产品一个耐磨保护层，同时创造一个油的效果。
- 2 第一层：3/4毫米名贵实木层（取决于优异的选材和表面加工），四边微倒角处理。
- 3 中间层（3-11）：由9层100%全桦木基材，纵横交错组成，使得整体结构超强坚韧及稳定（12mm厚度）。
- 4 底层：防水漆面处理。由一层孔隙填料清漆制成，有助于确保地板紧凑的平面配置。



# STRUCTURE

ESTRUCTURA / STRUTTURA / 结构

**FiorWood®**  
SLIM 3 LAYER TECHNOLOGY

## ENG

- 1 FINISH. 12 coats of High Traffic varnish. Brushed open pore grain that highlights the natural essence of the wood.
- 2 TOP LAYER. 0,6 mm NOBLE WOOD, micro-bevelled.
- 3 CORE. 9 mm 100% birch plywood.
- 4 SUBSTRUCTURE. Contra-balance 0,6 mm wood veneer with a finishing coat of varnish for extra stability and fire resistance.

## ESP

- 1 ACABADO. 12 manos de barniz Alto Tráfico. El acabado cepillado de poro abierto resalta la esencia natural de la madera.
- 2 CAPA SUPERIOR. MADERA NOBLE de 0,6 mm microbiselada.
- 3 NÚCLEO. 9 mm de fenólico contrachapado 100% abedul.
- 4 INFRAESTRUCTURA. Contrapeso de 0,6 mm chapado en madera con una capa final de barniz para mayor estabilidad y resistencia al fuego.



## IT

- 1 FINITURA. 12 mani di vernice High Traffic. La venatura spazzolata a poro aperto evidenzia l'essenza naturale del legno.
- 2 STRATO SUPERIORE. 0,6 mm LEGNO NOBILE, microbisellato.
- 3 NUCLEO. 9 mm di multistrato di betulla 100%.
- 4 SOTTO-STRUTTURA. Controbilancio 0,6 mm impiallacciatura di legno con uno strato di vernice finale per maggiore stabilità e resistenza al fuoco.

## CN

- 1 表面处理：12 层高流量清漆。拉丝开孔纹理凸显了木材的自然本质。
- 2 顶层：0.6 毫米贵族木材，微倒角。
- 3 中间层：9毫米 100% 桦木胶合板。
- 4 底层结构：0.6 毫米木平衡层，涂有清漆涂层，具有额外的稳定性和防火性。

**Premium<sup>16</sup>**

## ENG

- 5 BASE. 6 mm 100% birch plywood. Total thickness: 16mm

## ESP

- 5 BASE. 6 mm de contrachapado 100% abedul. Espesor total: 16 mm



## IT

- 5 BASE. 6 mm di multistrato di betulla 100%. Spessore totale: 16 mm

## CN

- 5 基材：6 毫米 100% 桦木胶合板。总厚度：16mm



# STRUCTURE

ESTRUCTURA / STRUTTURA / 结构

**Woodpeak®**  
LIVING GREEN FLOORS

## ENG

- 1 FINISH. 12 coats of High Traffic varnish. Brushed open pore grain that highlights the natural essence of the wood.
- 2 TOP LAYER. 0,6 mm NOBLE WOOD, micro-bevelled.
- 3 CORE. 9 mm HDF (High-Density Fibreboard, with density >900kg/m<sup>3</sup>)
- 4 SUBSTRUCTURE. Contra-balance 0,6 mm wood veneer with a finishing coat of varnish for extra stability and fire resistance.

## ESP

- 1 ACABADO. 12 manos de barniz Alto Tráfico. El acabado cepillado de poro abierto resalta la esencia natural de la madera.
- 2 CAPA SUPERIOR. MADERA NOBLE de 0,6 mm microbiselada.
- 3 NÚCLEO. HDF de 9 mm (Tablero de fibras de alta densidad, con densidad > 900kg/m<sup>3</sup>)
- 4 INFRAESTRUCTURA. Contrapeso de 0,6 mm chapado en madera con una capa final de barniz para mayor estabilidad y resistencia al fuego.

**Premium<sup>16</sup>**

## ENG

- 5 BASE. 6 mm 100% birch plywood. Total thickness: 16mm

## ESP

- 5 BASE. 6 mm de contrachapado 100% abedul. Espesor total: 16 mm



## IT

- 1 FINITURA. 12 mani di vernice High Traffic. La venatura spazzolata a poro aperto evidenzia l'essenza naturale del legno.
- 2 STRATO SUPERIORE. 0,6 mm LEGNO NOBILE, microbisellato.
- 3 NUCLEO. HDF da 9 mm (pannello di fibra ad alta densità, con densità >900 kg/m<sup>3</sup>)
- 4 SOTTO-STRUTTURA. Controbilancio 0,6 mm impiallacciatura di legno con uno strato di vernice finale per maggiore stabilità e resistenza al fuoco.

## CN

- 1 表面处理：12 层高流量清漆。 拉丝开孔纹理凸显了木材的自然本质。
- 2 顶层： 0.6 毫米贵族木材，微倒角。
- 3 中间层： 9毫米HDF（高密度纤维板，密度>900kg/m<sup>3</sup>）
- 4 底层结构： 0.6 毫米木平衡层，涂有清漆涂层，具有额外的稳定性和防火性。

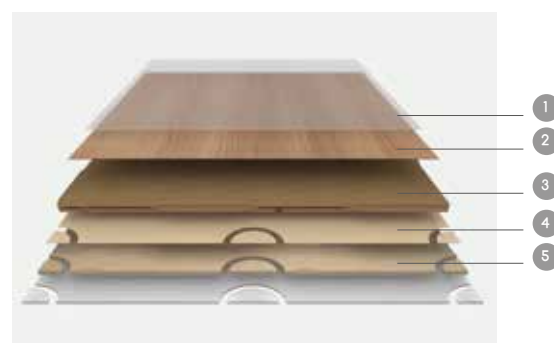

## IT

- 5 BASE. 6 mm di multistrato di betulla 100%. Spessore totale: 16 mm

## CN

- 5 基材： 6 毫米 100% 桦木胶合板。 总厚度： 16mm





100% Made in Spain



# BENEFITS

VENTAJAS / VANTAGGI / 优点

## LOCKSTP®

EXCELLENT GLUELESS SYSTEM

Glueless System Patent-protected worldwide

- 100% MADE IN SPAIN
- LARGE SELECTION OF COLORS, STYLES AND FORMATS
- MODULAR SYSTEM, BASED ON A PRECISE ALTERNATING TONGUE & GROOVE SYSTEM WHICH, TOGETHER WITH THE INTERLOCKING RINGS, PROVIDES THE PRODUCT A GREAT DIMENSIONAL STABILITY AND HUMIDITY RESISTANCE AS A PERFECT BOND WITHOUT THE NEED OF ADHESIVES
- CE MARKING
- FSC CERTIFIED
- SUITABLE FOR UNDERFLOOR HEATING
- COMMITTED TO THE ENVIRONMENT
- UNIQUE, FLEXIBLE & UNLIMITED DESIGNS
- PERFECT STRAIGHT FLOORBOARDS, WITH CONTRA-BALANCE WOOD VENEER FOR EXTRA STABILITY, AND A LAYER OF ANTIFLAME PRIMER TO IMPROVE THE FIRE RESISTANCE AND AVOID THE HUMIDITY EXCESS
- ANTIBACTERIAL
- BIOLOGICAL DURABILITY (EN 335-1 & 2): CLASS 1
- FORMALDEHYDE EMISSION (EN 717-2): E1. LOCKSTP PRODUCTS EMISSION IS 97% LOWER THAN THE MAXIMUM ALLOWED

**WOOD+**<sup>®</sup>  
MORE THAN WOOD

**FiorWood**<sup>®</sup>  
SLIM 3 LAYER TECHNOLOGY

**Woodpeak**<sup>®</sup>  
LIVING GREEN FLOORS

- 12 LAYERS OF ANTI-CRACKING VARNISHING
- WIRE BRUSHED FINISH, OPEN PORE, WHICH HIGHLIGHTS THE ESSENCE OF THE WOOD
- 3MM OF NOBLE WOOD AT THE TOP LAYER, SELECT WOOD WITH NO KNOTS, WHICH GIVES A CONTEMPORARY HIGH-END STYLE
- 12MM CORE, MADE OF 9 ALTERNATING LAYERS OF 100% BIRCH ENGINEERED PLYWOOD, PROVIDES THE PRODUCT A GREAT DIMENSIONAL STABILITY AND HUMIDITY RESISTANCE
- TWO LAYERS PRODUCT, STRONGER, MORE STABLE AND STRAIGHT THAN A HARDWOOD FLOOR
- VERY HIGH-END PRODUCT, SUITABLE FOR RESIDENTIAL AND COMMERCIAL PURPOSES
- FIRE RATING (EN-13501): CLASS C fl-s1
- VOCs EMISSION (ISO 16000-6:2006): A+ (< 1000 µg/m<sup>3</sup>)

- HIGH TRAFFIC RESISTANT COATINGS
- WIRE BRUSHED FINISH, OPEN PORE, WHICH HIGHLIGHTS THE ESSENCE OF THE WOOD
- 0,6MM OF NOBLE WOOD AT THE TOP LAYER, SO IT KEEPS THE FEELING AND WARMNESS OF THE REAL WOOD, BETTER THAN A SIMPLE LAMINATE
- 9MM CORE, MADE OF 7 ALTERNATING LAYERS OF 100% BIRCH ENGINEERED PLYWOOD, PROVIDES THE PRODUCT A GREAT DIMENSIONAL STABILITY AND HUMIDITY RESISTANCE
- ECO-SUSTAINABLE FLOORS, COMPOSED OF OPTIMIZED RAW MATERIALS, USING A THINNER LAYER OF THE NATURAL RESOURCE
- AUTHENTIC REAL WOOD, AT FAIR PRICES
- FIRE RATING (EN-13501): CLASS C fl-s1
- VOCs EMISSION (ISO 16000-6:2006): A+ (< 1000 µg/m<sup>3</sup>)

- HIGH TRAFFIC RESISTANT COATINGS
- WIRE BRUSHED FINISH, OPEN PORE, WHICH HIGHLIGHTS THE ESSENCE OF THE WOOD
- 0,6MM OF NOBLE WOOD AT THE TOP LAYER, SO IT KEEPS THE FEELING AND WARMNESS OF THE REAL WOOD, BETTER THAN A SIMPLE LAMINATE
- 9MM CORE, MADE OF HDF (HIGH DENSITY FIBERBOARD), THAT MAKES THE PRODUCT INCREDIBLY HARD, RIGID, AND SHOCKPROOF
- ECO-SUSTAINABLE FLOORS, COMPOSED OF OPTIMIZED RAW MATERIALS, USING A THINNER LAYER OF THE NATURAL RESOURCE
- AUTHENTIC REAL WOOD, AT FAIR PRICES
- FIRE RATING (EN-13501): CLASS B fl-s1
- HIGH DENSITY FIBERBOARD, WITH DENSITY OVER 900kg/m<sup>3</sup>

100% Made in Spain

# SIZES

FORMATOS / FORMATI / 尺寸及样式

**WOOD<sup>+</sup>**  
MORE THAN WOOD

**FiorWOOD**  
SLIM 3 LAYER TECHNOLOGY

**Woodpeak**  
LIVING GREEN FLOORS

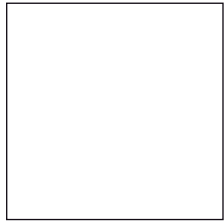

1160 x 1160  
45,67" x 45,67"



1160 x 580  
45,67" x 22,83"



1160 x 290  
45,67" x 11,42"

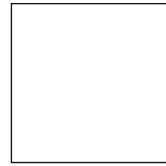

870 x 870  
34,25" x 34,25"



870 x 290  
34,25" x 11,42"

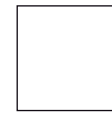

580 x 580  
22,83" x 22,83"



580 x 290  
22,83" x 11,42"



290 x 290  
11,42" x 11,42"

**W<sup>+</sup> LISTONE**

with LockSTP system, for floating installation  
con sistema LockSTP, para instalación flotante

con sistema LockSTP, per installazione flottante  
使用LockSTP安装系统, 可无胶悬浮安装。

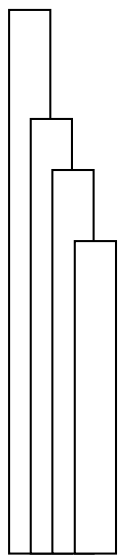

2900 - 2320 - 2030 - 1740 X 230  
114,17" - 91,34" - 79,92" - 68,50" X 9,06"



2320 - 2030 - 1740 X 195<sup>1</sup>  
91,34" - 79,92" - 68,50" X 7,68"

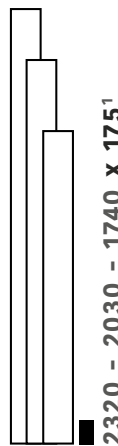

2320 - 2030 - 1740 X 175<sup>1</sup>  
91,34" - 79,92" - 68,50" X 6,89"

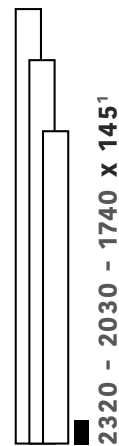

2320 - 2030 - 1740 X 145<sup>1</sup>  
91,34" - 79,92" - 68,50" X 5,71"

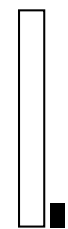

1160 X 145<sup>2</sup>  
45,67" X 5,71"

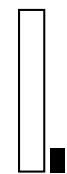

870 X 145<sup>2</sup>  
34,25" X 5,71"

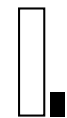

580 X 145<sup>2</sup>  
22,83" X 5,71"

<sup>1</sup>MIXED LENGTHS of 2320-2030-1740 MM. <sup>2</sup>Herringbone engineering, always 145 MM. width, available under request & subject to an extra cost.

<sup>1</sup>LARGOS MIXTOS ALEATORIOS de 2320-2030-1740 MM. <sup>2</sup>Mecanizado Herringbone, siempre ancho 145 MM., disponible bajo pedido y sujeto a un cargo extra.

3 STRIP - 68,4 WIDTH

2 STRIP - 102,5 WIDTH

1 STRIP - 205,1 WIDTH

1 STRIP- 145,0 WIDTH

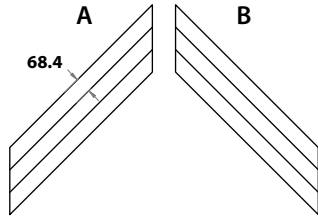

**870x205**  
34,25" x 8,07"

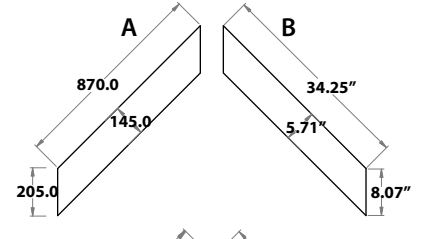
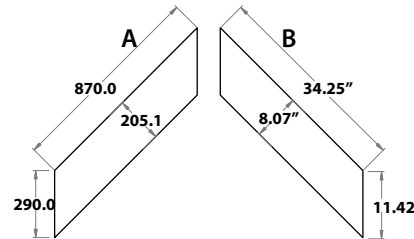
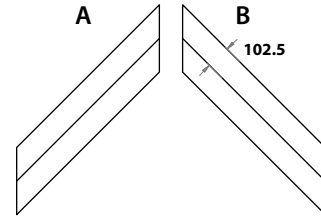

**870x145**  
34,25" x 5,71"

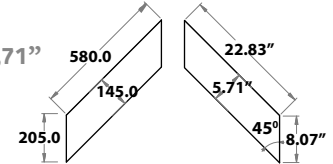

**580x145**  
22,83" x 5,71"

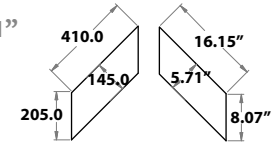

**410x145**  
16,15" x 5,71"

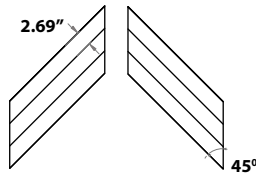

**580x205**  
22,83" x 8,07"

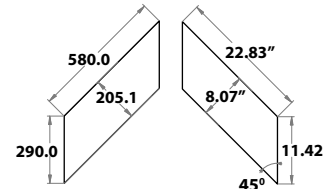
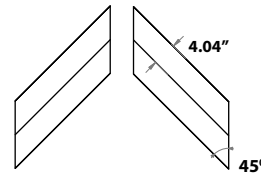

with traditional T&G system, for glue down installation  
con sistema tradicional T&G, para instalaci3n encolada

con sistema tradizionale T&G, per installazione incollata  
使用传统安装方式, 胶水安装。

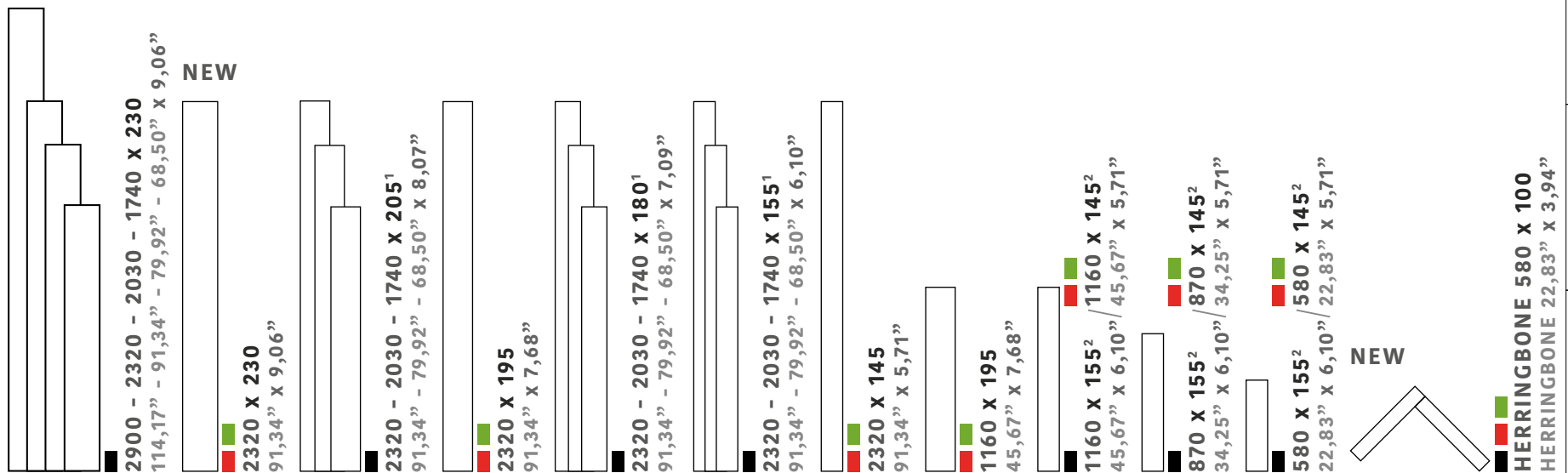

<sup>1</sup>LUNGHEZZE MISTE (RANDOM) di 2320-2030-1740 MM. <sup>2</sup>Sistema herringbone, sempre in larghezza 145 MM., disponibile su richiesta e soggetto a un costo adizionale.

<sup>1</sup>混合不等长, 长度为2320-2030-1740。 <sup>2</sup>可做人字拼, 宽度为145毫米, 可定制, 需加收额外费用。

\*Please see differences of the same pattern between the different divisions in Mounting Type section. / Consulte las diferencias del mismo patrón entre las diferentes divisiones en la sección Esquemas de montaje. / Si prega di vedere le differenze dello stesso modello tra le diverse divisioni nella sezione Schema di montaggio. / 请参见安装方案部分中不同分区之间相同图案的差异。

100% Made in Spain



■ ■ ■  
**MORISCO**  
290x290  
11,42"x11,42"



■ ■ ■  
**SQUAMA**  
290x290  
11,42"x11,42"



■ ■ ■  
**SHURIKEN**  
290x290  
11,42"x11,42"



■ ■ ■  
**DIAMOND**  
502x290  
19,77"x11,42"



■ ■ ■  
**DADOS**  
290x290  
11,42"x11,42"

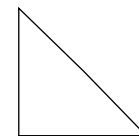

■ ■ ■  
**TRIANGLE**  
580x580  
22,83"x22,83"



■ ■ ■  
**SILHOUETTE**  
580x429  
22,83"x16,90"

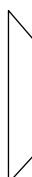

■ ■ ■  
**TRAPEZIUM 870**  
870x145  
34,25"x5,71"



■ ■ ■  
**TRAPEZIUM 580**  
580x145  
22,83"x5,71"

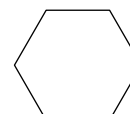

■ ■ ■  
**HEXAGON 580**  
580x502  
22,83"x19,76"



■ ■ ■  
**HEXAGON 290**  
290x251  
11,42"x9,88"

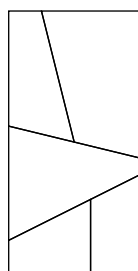

■ ■ ■  
**TRENCADIS\***  
1160x580  
45,67"x22,83"



■ ■ ■  
**RHOMBUS\***  
1160x290  
45,67"x11,42"



■ ■ ■  
**MULTILINE**  
870x290  
34,25"x11,42"



■ ■ ■  
**MULTILINE**  
580x580  
22,83"x22,83"

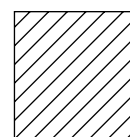

■ ■ ■  
**45°**  
580x580  
22,83"x22,83"

## MULTI-RIGATO

NEW

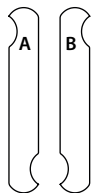

**HERRINGBONE CHAIN SIMPLE**  
870x145  
34,25"x5,71"

NEW

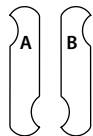

**HERRINGBONE CHAIN SIMPLE**  
580x145  
22,83"x5,71"

NEW

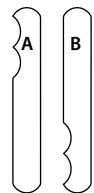

**HERRINGBONE CHAIN DOUBLE**  
870x145  
34,25"x5,71"

NEW

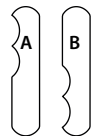

**HERRINGBONE CHAIN DOUBLE**  
580x145  
22,83"x5,71"

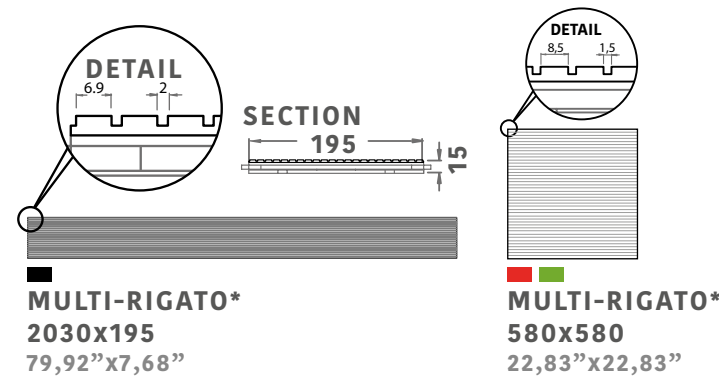

**MULTI-RIGATO\***  
2030x195  
79,92"x7,68"

**MULTI-RIGATO\***  
580x580  
22,83"x22,83"

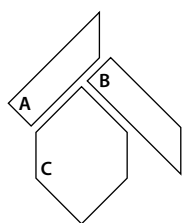

**BRAID A / B**  
580x145  
22,83"x5,71"

**BRAID C**  
615x410  
24,21"x16,14"

## LOOPING 8

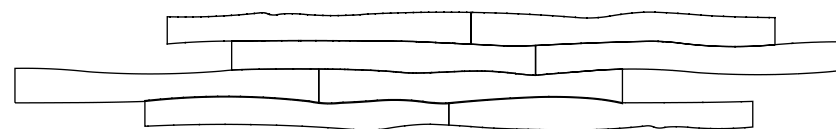

**LOOPING 8\***  
2030x230  
79,92"x9,06"

**LOOPING 8\***  
2030x205  
79,92"x8,07"

**LOOPING 8\***  
2320x230  
91,34"x9,06"

## MULTILINE

NEW

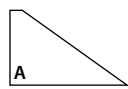

**LINK 580 A**  
525x341  
20,67"x13,43"

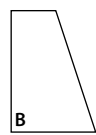

**LINK 580 B**  
380x552  
14,96"x21,73"

**BICOLOR MAPLE NATURAL**  
**A. WALNUT NATURAL**

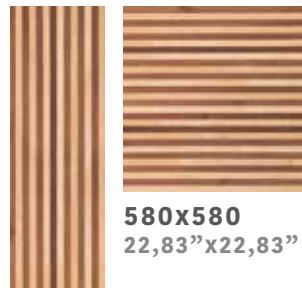

**870x290**  
34,25"x11,42"

**580x580**  
22,83"x22,83"

**A. WALNUT NATURAL**

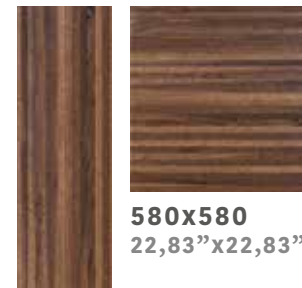

**870x290**  
34,25"x11,42"

**580x580**  
22,83"x22,83"

**INFINITY LINE**

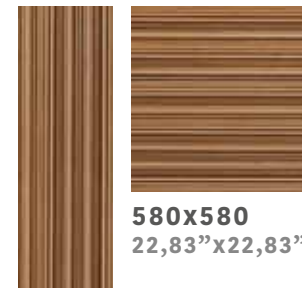

**870x290**  
34,25"x11,42"

**580x580**  
22,83"x22,83"

100% Made in Spain

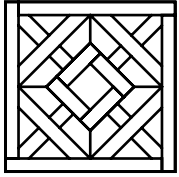

ALHAMBRA  
580x580  
22,83"x22,83"

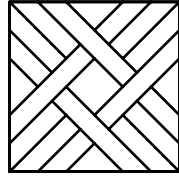

ARGYLE  
580x580  
22,83"x22,83"

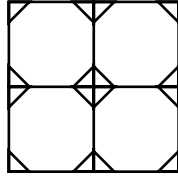

BEAUVALLON  
580x580  
22,83"x22,83"

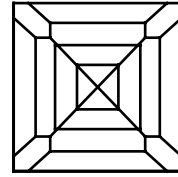

BUCKINGHAM  
580x580  
22,83"x22,83"

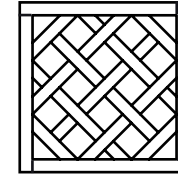

CAPODIMONTE  
580x580  
22,83"x22,83"

NEW

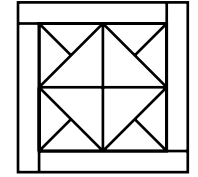

CASPIAN  
580x580  
22,83"x22,83"

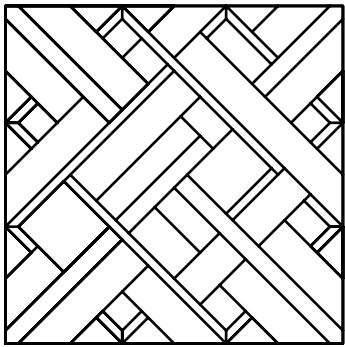

BOUCHERON  
1160x1160  
45,67"x45,67"

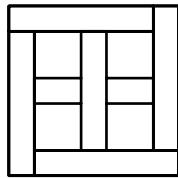

CROSS CASSETTE  
580x580  
22,83"x22,83"

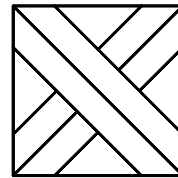

DOHA  
580x580  
22,83"x22,83"

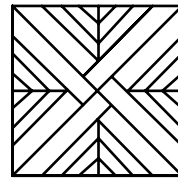

FONTAINEBLEAU  
580x580  
22,83"x22,83"

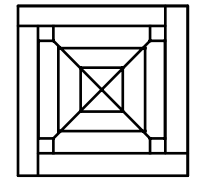

HERMITAGE  
580x580  
22,83"x22,83"

NEW

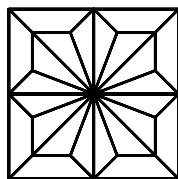

KUCUKSU  
580x580  
22,83"x22,83"

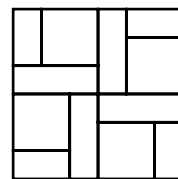

MINIU  
580x580  
22,83"x22,83"

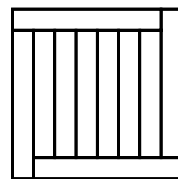

MONET  
580x580  
22,83"x22,83"

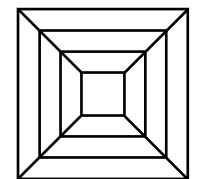

PALAIS ROYAL  
580x580  
22,83"x22,83"

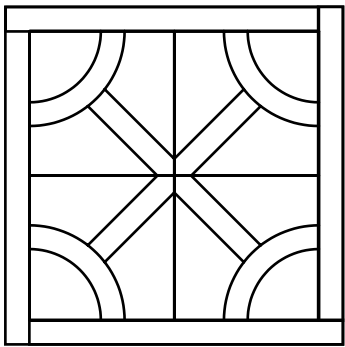

CHANTILLY  
1160x1160 / 580x580  
45,67"x45,67" / 2,83"x22,83"

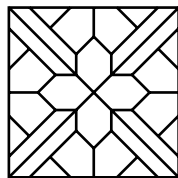

POTALA  
580x580  
22,83"x22,83"

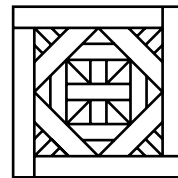

TAJ MAHAL  
580x580  
22,83"x22,83"

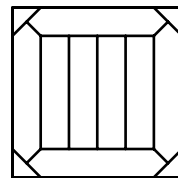

TOP KAPI  
580x580  
22,83"x22,83"

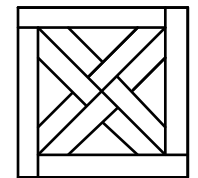

VERSAILLES  
580x580  
22,83"x22,83"

■  
**290 x 290**  
11,42"x11,42"

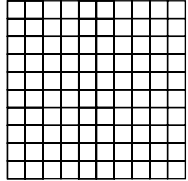

**30 x 30**  
1,18"x1,18"

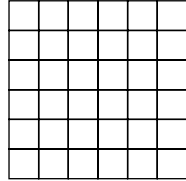

**50 x 50**  
1,97"x1,97"

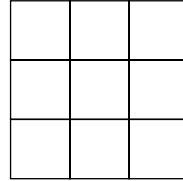

**100 x 100**  
3,94"x3,94"

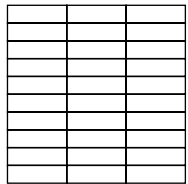

**100 x 30**  
3,94"x1,18"

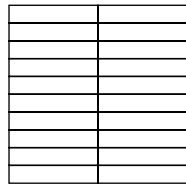

**150 x 30**  
5,91"x1,18"

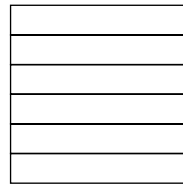

**290 x 50**  
11,42"x1,97"

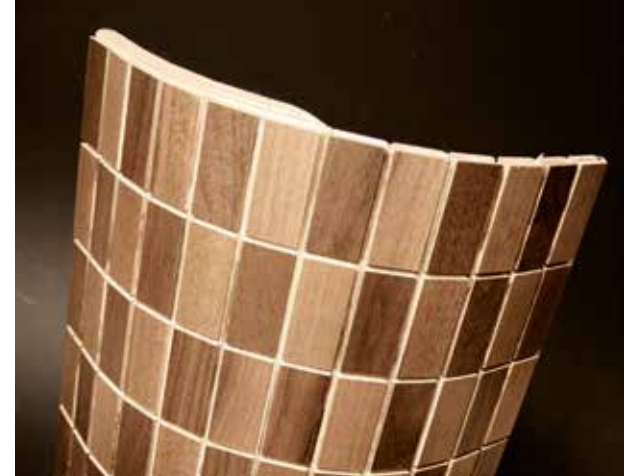

☒ Flexible format available under request.  
Formato flexible disponible bajo pedido.  
Formato flessibile disponibile su richiesta.  
可定制尺寸.



WoodMosaic 290x290 A. Walnut Natural - 50x50 Tessere



# COLORS

COLORES / COLORI / 花色



## OAK

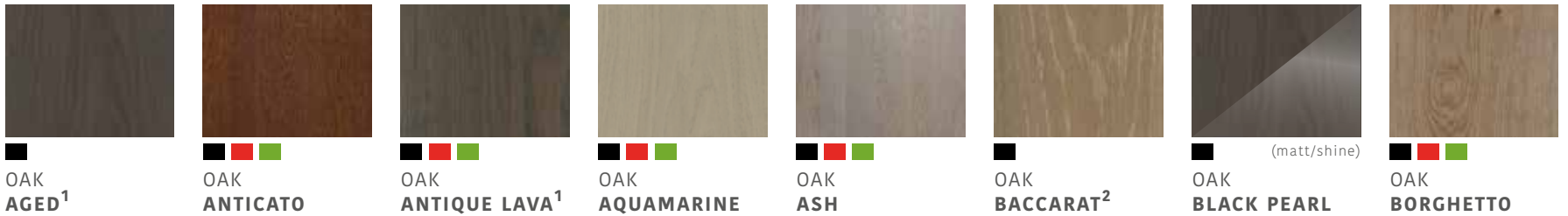

## OAK

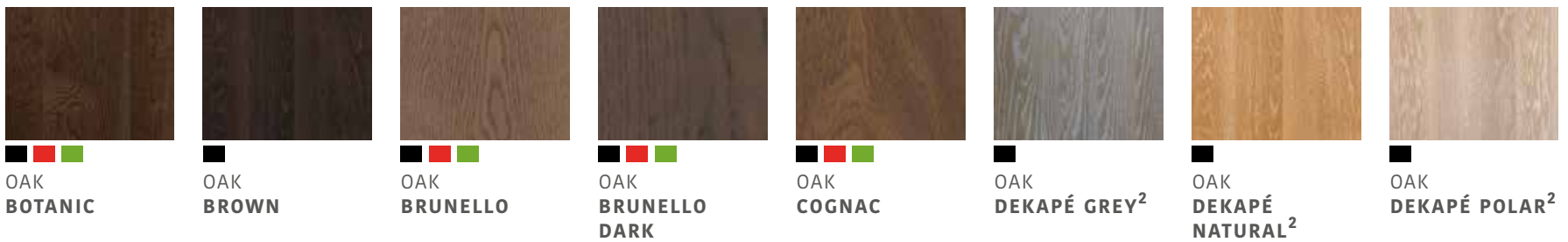

## OAK

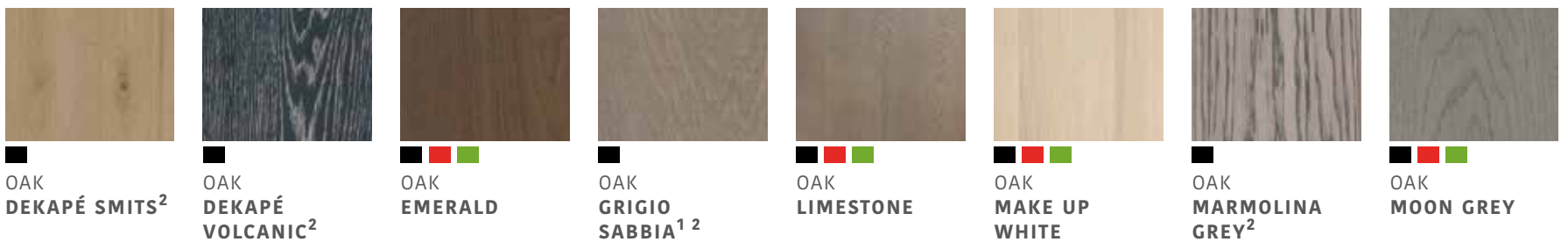

## OAK

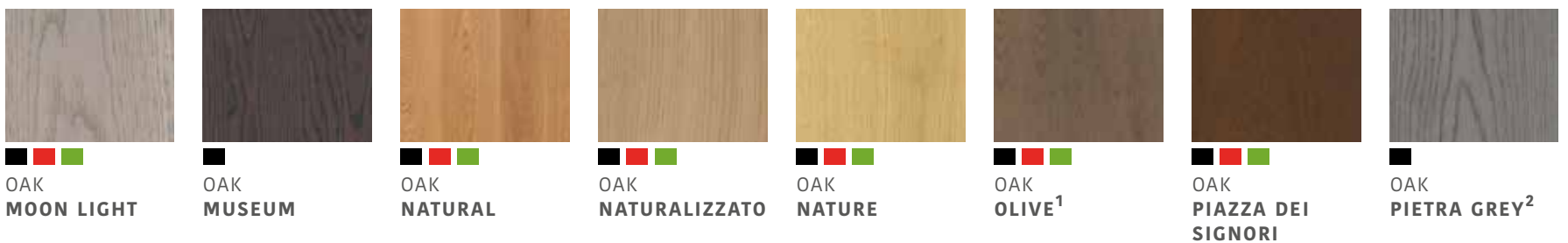

**ENG 1.** Color & tone may vary from plank to plank due to reactive stain. **2.** Dekape color. **3.** Lacquered color, resistant to moderate traffic **4.** Wood colors may not be exactly as illustrated due to variations during printing. Always refer to the color samples in store. **5.** All exotic species are subject to availability, especially for W+Listone/Tavole STP and Chevron series. **ESP 1.** El color y tono pueden variar de tabla a tabla debido al tinte reactivo. **2.** Color Dekape. **3.** Color lacado, resistente al tráfico moderado. **4.** Debido a las variaciones causadas por el proceso de impresión, los colores de la madera representados en este documento son sólo de referencia. Consulte siempre las muestras de color disponibles en los puntos de venta. **5.** Todas las especies exóticas están sujetas a disponibilidad, especialmente para las series

## OAK

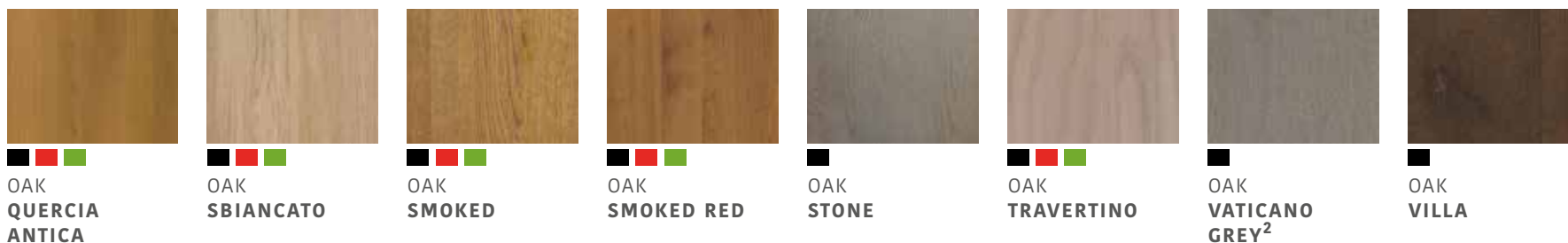

OAK  
QUERCIA  
ANTICA



OAK  
SBIANCATO



OAK  
SMOKED



OAK  
SMOKED RED



OAK  
STONE



OAK  
TRAVERTINO



OAK  
VATICANO  
GREY<sup>2</sup>



OAK  
VILLA

## METALLIZZATI

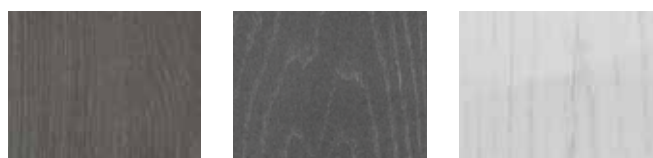

OAK  
FOUR  
SEASONS<sup>2 3</sup>



OAK  
LAVA DARK<sup>3</sup>



OAK  
MCLAREN<sup>3</sup>

## DELUX OAK

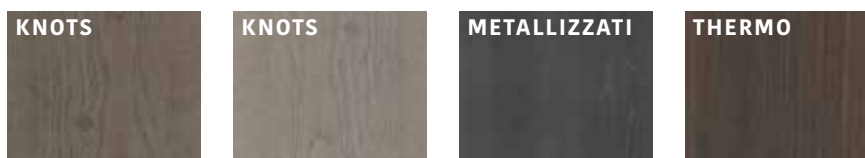

OAK  
AGED<sup>1</sup>



OAK  
AGED  
SBIANCATO<sup>1</sup>



OAK  
LAVA DARK<sup>3</sup>



OAK  
MOCCA<sup>1</sup>

## TINTE UNITE



OAK  
CHERRY<sup>3</sup>



OAK  
EXTRA WHITE<sup>3</sup>  
(matt/shine)



OAK  
GRIGIO  
CEMENTO<sup>3</sup>



OAK  
GRIGIO PERLA<sup>3</sup>



OAK  
INDIGO<sup>3</sup>



OAK  
MENTHA<sup>3</sup>



OAK  
TORTORA<sup>3</sup>



OAK  
TURQUOISE<sup>3</sup>

## AMERICAN WALNUT



AMERICAN  
WALNUT  
ANTIQUE<sup>1</sup>



AMERICAN  
WALNUT  
ASH



AMERICAN  
WALNUT  
CAOBA-LUX



AMERICAN  
WALNUT  
HONEY  
EXOTIC



AMERICAN  
WALNUT  
LIGHT



AMERICAN  
WALNUT  
NATURAL



AMERICAN  
WALNUT  
SBIANCATO



IROKO  
NATURAL<sup>5</sup>



JATOBA  
NATURAL<sup>5</sup>



MAPLE  
ICEBERG<sup>5</sup>



MAPLE  
NATURAL<sup>5</sup>



TEAK ASIA  
NATURAL<sup>5</sup>



WENGE  
DARK<sup>5</sup>



WENGE  
NATURAL<sup>5</sup>

W+Listone/Tavole STP y Chevron. **IT 1.** Color e tono possono variare da tavola a tavola a causa della vernice reattiva. **2.** Colore Dekape. **3.** Colore laccato, resistente al traffico moderato. **4.** A causa delle variazioni dovute al processo di stampa, i colori del legno rappresentati in questo documento sono solo indicativi. Si prega di visionare i campioni disponibili in negozio. **5.** Tutte le specie esotiche sono soggette a disponibilità, in particolare per le serie W+Listone/Tavole STP e Chevron. **CN 1.** 由于反应性染色，不同地板的颜色和色调可能不同。 **2.** 表面颜色拉丝处理工艺。 **3.** 漆色，耐中等交通。 **4.** 地板实物颜色可能与图片略有差别，请以实样为准 **5.** 特殊木种视资源情况而定，尤其是直板和鱼骨拼系列

# FINISHES

ACABADOS / FINITURE / 成品

**WOOD<sup>+</sup>**  
MORE THAN WOOD

## STANDARD FINISH

### CLASSIC



CLASSIC is a UV brushed finish, with “oil-effect”, micro-beveled on all four sides, open pore, resistant to moderate traffic. Gloss 5.

CLASSIC es un acabado UV cepillado, con “efecto aceite”, micro-biselado en los cuatro lados, poro abierto, resistente al tráfico moderado. Gloss 5.

CLASSIC è una finitura spazzolata UV, ad “effetto olio”, micro-bisellato sui quattro lati, poro aperto, resistente al traffico moderato. Gloss 5.

经典精选;经典精选工艺是一种UV面漆处理,具有油效,四边微倒角,开放孔,适度耐磨。光泽度5度。

### TRADITIONAL



TRADITIONAL is a UV brushed finish, with “oil-effect”, micro-beveled on all four sides, open pore, with knots, resistant to moderate traffic. Gloss 5.

TRADITIONAL es un acabado UV cepillado, con “efecto aceite”, micro-biselado en los cuatro lados, poro abierto, con nudos, resistente al tráfico moderado. Gloss 5.

TRADITIONAL è una finitura spazzolata UV, ad “effetto olio”, micro-bisellato sui quattro lati, poro aperto, con nodi, resistente al traffico moderato. Gloss 5.

传统系列;传统系列是一种UV面漆处理,具有油效,四边微倒角,开放孔,有结疤,适度耐磨。光泽度5度。

## SPECIAL FINISH

### TRAFFIC-BRUSHED



TRAFFIC-BRUSHED is a UV brushed finish, with semi-gloss effect, micro-beveled on all four sides, open pore, resistant to intense traffic. Gloss 15.

TRAFFIC-BRUSHED es un acabado UV cepillado, con efecto satinado, micro-biselado en los cuatro lados, poro abierto, resistente al tráfico intenso. Gloss 15.

TRAFFIC-BRUSHED è una finitura spazzolata UV, con effetto semilucido, micro-bisellato sui quattro lati, poro aperto, resistente al traffico intenso. Gloss 15.

耐磨涂刷 耐磨涂刷是一种UV面漆处理,具有半光亮的表面效果,四边微倒角,开放孔,极其耐磨。光泽度15度。

### SHINE



SHINE is a UV brushed finish, with high gloss effect, micro-beveled on all four sides, open pore, resistant to moderate traffic. Gloss 85.

SHINE es un acabado UV cepillado, con efecto alto brillo, micro-biselado en los cuatro lados, poro abierto, resistente al tráfico moderado. Gloss 85.

SHINE è una finitura spazzolata UV, con effetto lucido, micro-bisellato sui quattro lati, poro aperto, resistente al traffico moderato. Gloss 85.

高光系列 高光系列是一种UV面漆处理,具有高光亮度的效果,四边微倒角,开放孔,适度耐磨。光泽度85度

Nominal top layer thickness is measured prior to the finishing process. Finishing process such as wire brushing, hand-scraped or sawcut may affect the overall thickness or bevels.

El espesor nominal se mide antes del proceso de acabado. Acabados con cepillado, cepillado a mano o corte sierra pueden afectar al espesor total o el bisel.

Lo spessore nominale dello strato superiore è misurato prima del processo di finitura. Processi di finitura quali spazzolatura, piallato a mano o taglio a sega possono alterare lo spessore complessivo o il bisello.

厚度是指加工前测量的,表层处理工艺,比如涂刷、手刮仿古或者锯齿纹理等处理后会影响最终整体厚度及倒角斜面。

**FiorWOOD**  
SLIM 3 LAYER TECHNOLOGY

**Woodpeak**  
LIVING GREEN FLOORS

## STANDARD

## STANDARD

### LUX

### HAND-SCRAPED

### CROSS-CUT

### TRAFFIC-BRUSHED

### TRAFFIC-BRUSHED



LUX is a UV finish, with semi-gloss effect, micro-beveled on all four sides, close pore, smooth surface without brushing, resistant to moderate traffic. Gloss 25.

HAND-SCRAPED is a UV brushed finish with hand-scraped, with "oil-effect", micro-beveled on all four sides prior to the finishing process, open pore, resistant to moderate traffic. Gloss 5.

CROSS-CUT is a UV brushed finish with cross-cut saw, with "oil-effect", micro-beveled on all four sides prior to the finishing process, open pore, resistant to moderate traffic. Gloss 5.

TRAFFIC-BRUSHED is a UV brushed finish, with semi-gloss effect, micro-beveled on all four sides, open pore, resistant to intense traffic. Gloss 15.

TRAFFIC-BRUSHED is a UV brushed finish, with semi-gloss effect, micro-beveled on all four sides, open pore, resistant to intense traffic. Gloss 15.

LUX es un acabado UV, con efecto satinado, micro-biselado en los cuatro lados, poro cerrado, superficie lisa sin cepillado, resistente al tráfico moderado. Gloss 25.

HAND-SCRAPED es un acabado UV con cepillado a mano, con "efecto aceite", micro-biselado en los cuatro lados antes del proceso de acabado, poro abierto, resistente al tráfico moderado. Gloss 5.

CROSS-CUT es un acabado UV cepillado con efecto de corte sierra transversal, con "efecto aceite", micro-biselado en los cuatro lados antes del proceso de acabado, poro abierto, resistente al tráfico moderado. Gloss 5.

TRAFFIC-BRUSHED es un acabado UV cepillado, con efecto satinado, micro-biselado en los cuatro lados, poro abierto, resistente al tráfico intenso. Gloss 15.

TRAFFIC-BRUSHED es un acabado UV cepillado, con efecto satinado, micro-biselado en los cuatro lados, poro abierto, resistente al tráfico intenso. Gloss 15.

LUX è una finitura UV, con effetto semilucido, micro-bisellato sui quattro lati, poro chiuso, superficie liscia senza spazzolatura, resistente al traffico moderato. Gloss 25.

HAND-SCRAPED è una finitura spazzolata UV piattato a mano, ad "effetto olio", micro-bisellato sui quattro lati prima della finitura, poro aperto, resistente al traffico moderato. Gloss 5.

CROSS-CUT è una finitura spazzolata UV effetto taglio sega, ad "effetto olio", micro-bisellato sui quattro lati prima della finitura, poro aperto, resistente al traffico moderato. Gloss 5.

TRAFFIC-BRUSHED è una finitura spazzolata UV, con effetto semilucido, micro-bisellato sui quattro lati, poro aperto, resistente al traffico intenso. Gloss 15.

TRAFFIC-BRUSHED è una finitura spazzolata UV, con effetto semilucido, micro-bisellato sui quattro lati, poro aperto, resistente al traffico intenso. Gloss 15.

光亮系列 光亮系列是一种UV面漆处理, 具有半光亮的表面效果, 四边微倒角, 封闭孔, 表面光滑无涂刷工艺, 适度耐磨。光泽度25度

手刮仿古 手刮仿古系列是一种UV漆, 手刮拉丝涂刷工艺, 具有油效, 四边微倒角, 开放孔, 适度耐磨。光泽度5度。

锯齿拉丝 锯齿拉丝系列是一种UV漆, 交叉锯齿纹理工艺, 具有油效, 四边微倒角, 开放孔, 适度耐磨。光泽度5度。

耐磨涂刷 耐磨涂刷是一种UV面漆处理, 具有半光亮的表面效果, 四边微倒角, 开放孔, 极其耐磨。光泽度15度。

耐磨涂刷 耐磨涂刷是一种UV面漆处理, 具有半光亮的表面效果, 四边微倒角, 开放孔, 极其耐磨。光泽度15度。

100% Made in Spain

# MOUNTING SCHEMES

ESQUEMAS DE MONTAJE / SCHEMI DI MONTAGGIO / 安装方案



STANDARD FINISH		SPECIAL FINISH				STANDARD	STANDARD
CLASSIC	TRADITIONAL	TRAFFIC	SHINE	LUX	HAND-SCRAPED	TRAFFIC	TRAFFIC

**JACK AND JACK ASSEMBLY / ESQUEMA DE MONTAJE LINEAL**  
**/ SCHEMA DI MONTAGGIO LINEARE / 直拼**

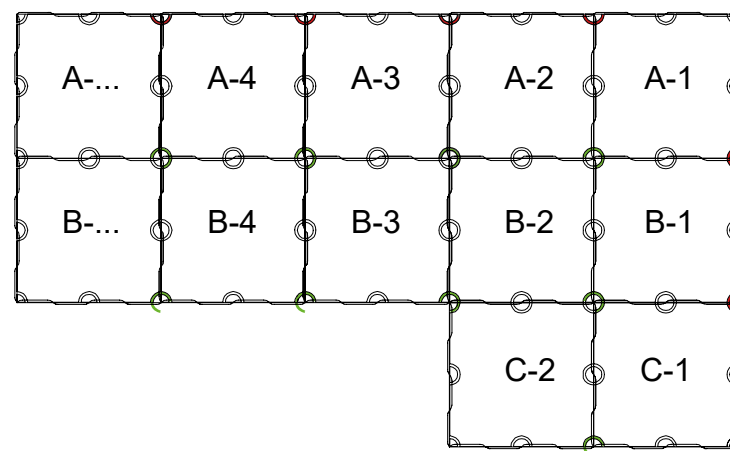
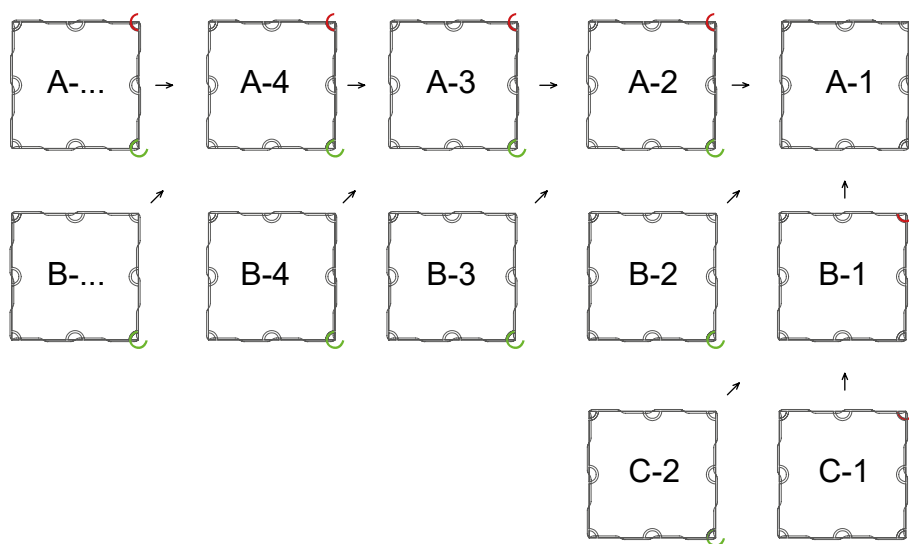

**HALF RUNNING BOND ASSEMBLY SCHEME / ESQUEMA DE MONTAJE TRABADO A MITAD**  
**/ SCHEMA DI MONTAGGIO SFALSATO A METÀ / 半错开装配方案**

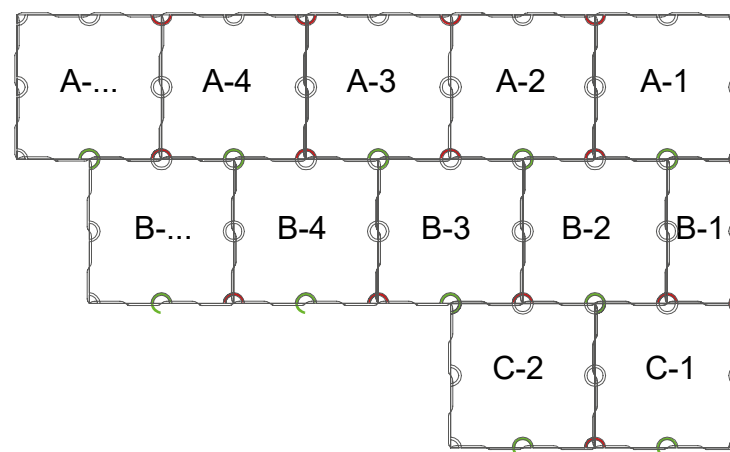
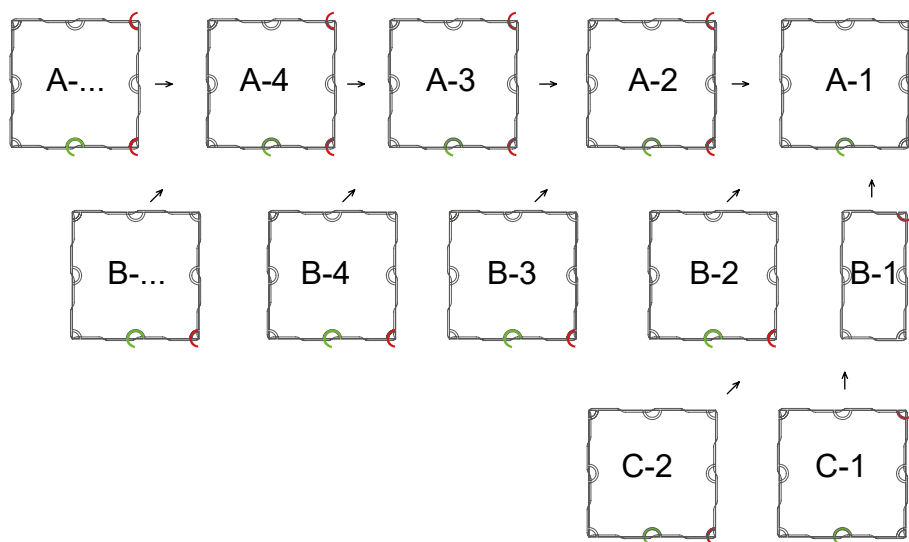

100% Made in Spain

ONE-THIRD RUNNING ASSEMBLY SCHEME / ESQUEMA DE MONTAJE TRABADO A UN TERCIO  
/ SCHEMA DI MONTAGGIO SFALSATO A UN TERZO / 三分之一错开装配方案

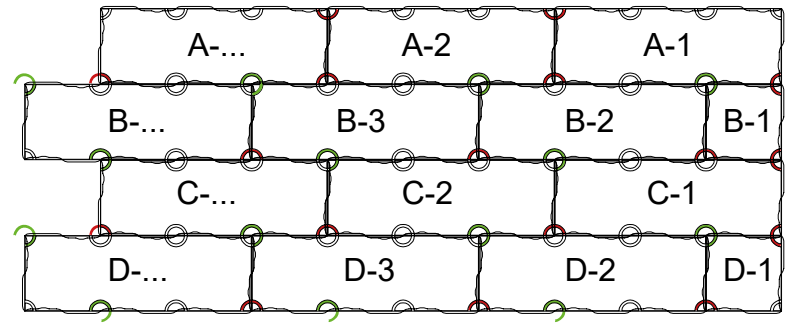
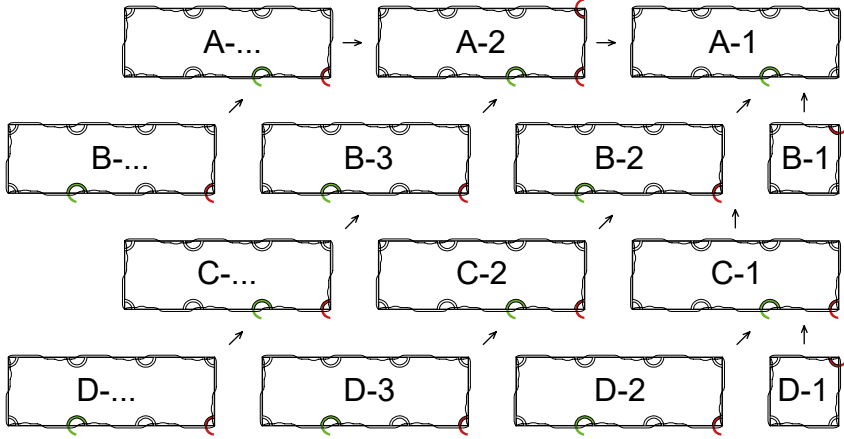



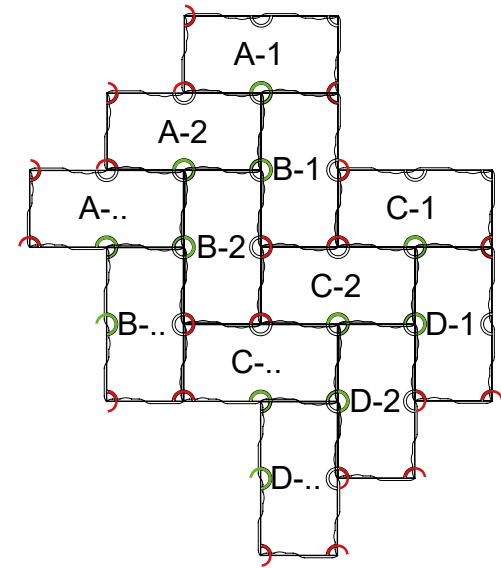
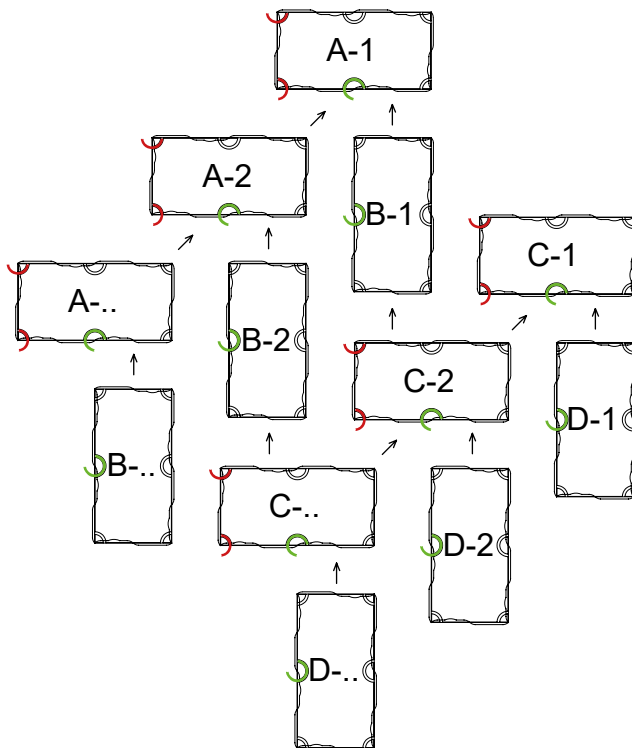

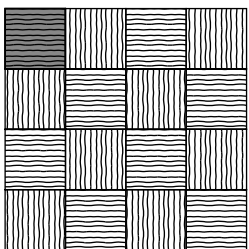
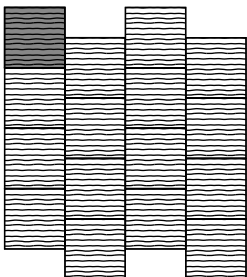
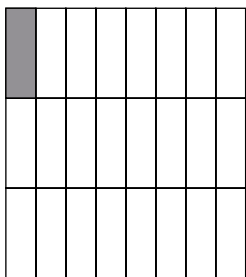
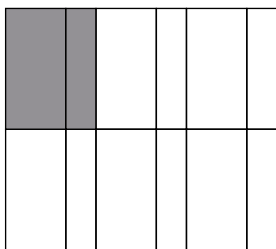
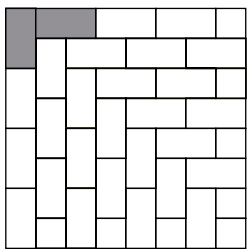
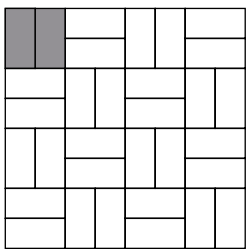
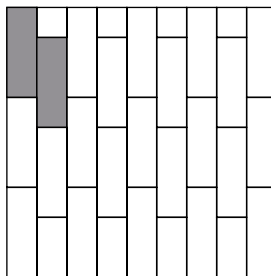
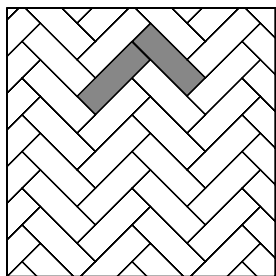
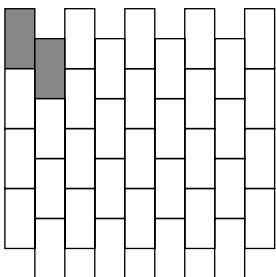
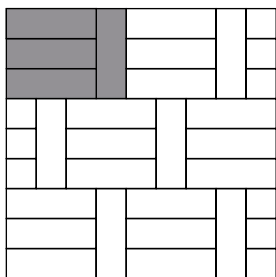
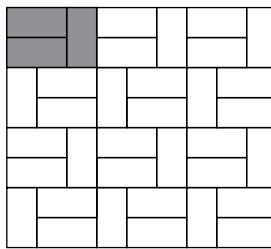
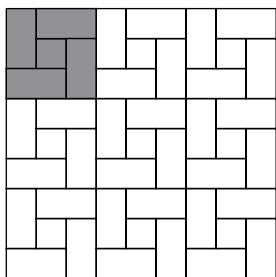





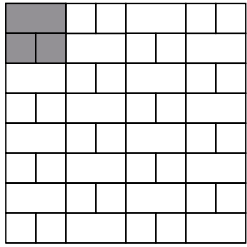
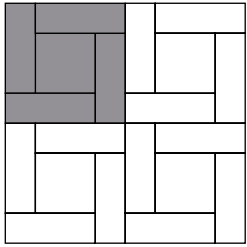
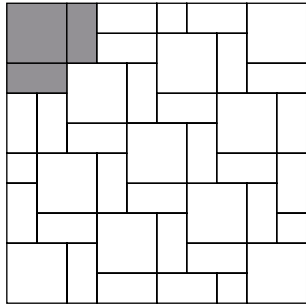
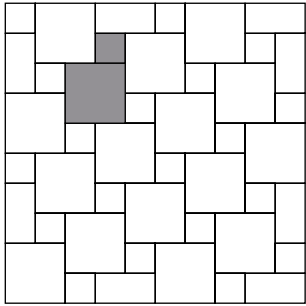

HERRINGBONE ASSEMBLY SCHEME / ESQUEMA DE MONTAJE DE ESPIGA  
/ SCHEMA DI MONTAGGIO A SPINA / 人字拼装配方案

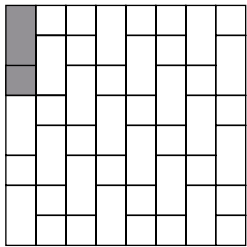
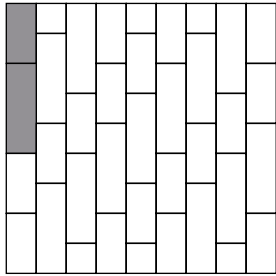
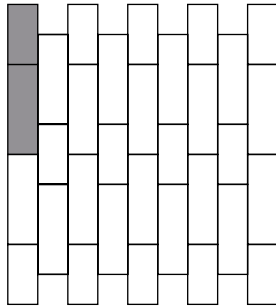
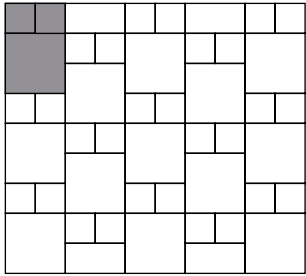

<b>A</b> ■ ■ ■		<b>B</b> ■ ■ ■		<b>C</b> ■ ■ ■		<b>D</b> ■ ■ ■	
Format	290x290 - 580x580	Format	290x290 - 580x580	Format	580x290 - 870x290 - 1160x290 - 1160x580	Format	1160x580
% m <sup>2</sup>	100 %	% m <sup>2</sup>	100 %	% m <sup>2</sup>	100 %	% m <sup>2</sup>	67 %
							
<b>E</b> ■ ■ ■		<b>F</b> ■ ■ ■		<b>G</b> ■ ■ ■		<b>H</b> ■ ■ ■	
Format	580x290 - 870x290 - 1160x290 - 1160x580	Format	580x290 - 1160x580	Format	870x290 - 1160x290 - 1160x580	Format	580x290 - 870x290 - 1160x290 - 1160x580
% m <sup>2</sup>	100 %	% m <sup>2</sup>	100 %	% m <sup>2</sup>	100 %	% m <sup>2</sup>	100 %
							
<b>I</b> ■ ■ ■		<b>J</b> ■ ■ ■		<b>K</b> ■ ■ ■		<b>L</b> ■ ■ ■	
Format	580x290 - 1160x290 - 1160x580	Format	870x290	Format	580x290 - 1160x580	Format	580x290 - 1160x580
% m <sup>2</sup>	100 %	% m <sup>2</sup>	100 %	% m <sup>2</sup>	100 %	% m <sup>2</sup>	89 %
							

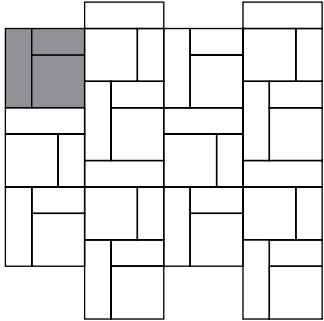
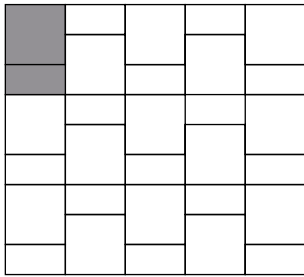
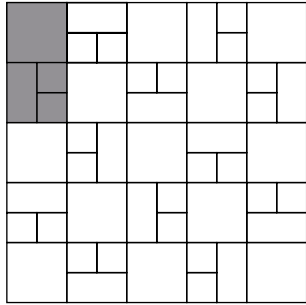
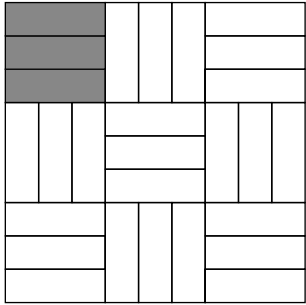

<b>M</b> 				<b>N</b> 				<b>O</b> 				<b>P</b> 			
Format	580x290 - 1160x580	290x290 - 580x580		Format	870x290	580x580		Format	580x580	580x290		Format	580x580	290x290	
% m <sup>2</sup>	50 %	50 %		% m <sup>2</sup>	75 %	25 %		% m <sup>2</sup>	50 %	50 %		% m <sup>2</sup>	80 %	20 %	
															
<b>Q</b> 				<b>R</b> 				<b>S</b> 				<b>T</b> 			
Format	580x290 - 1160x580	290x290 - 580x580		Format	870x290 - 1160x290	580x290 - 870x290		Format	870x290 - 1160x290	580x290 - 870x290		Format	580x580	290x290	
% m <sup>2</sup>	67 %	33 %		% m <sup>2</sup>	60 % - 57 %	40 % - 43 %		% m <sup>2</sup>	60 % - 57 %	40 % - 43 %		% m <sup>2</sup>	67 %	33 %	
															
<b>U</b> 				<b>V</b> 				<b>W</b> 				<b>X</b> 			
Format	580x580	870x290	580x290	Format	580x580	580x290		Format	580x580	580x290	290x290	Format	870x290		
% m <sup>2</sup>	45 %	33 %	22 %	% m <sup>2</sup>	67 %	33 %		% m <sup>2</sup>	50 %	25 %	25 %	% m <sup>2</sup>	100 %		
															

<b>Y</b>				<b>Z</b>				<b>AB</b>				<b>AC</b>			
Format	580x580	580x290	290x290	Format	580x580	580x290	290x290	Format	580x580	580x290	290x290	Format	580x580	580x290	290x290
% m <sup>2</sup>	57 %	29 %	14 %	% m <sup>2</sup>	44.5 %	44.5 %	11 %	% m <sup>2</sup>	44.5 %	44.5 %	11 %	% m <sup>2</sup>	25 %	50 %	25 %
<b>AD</b>			<b>AE</b>			<b>AF</b>			<b>AG</b>						
Format	580x580	290x290	Format	1160x1160	870x290	580x290	Format	1160x290 - 870x290			Format	1160x290	870x290	580x290	
% m <sup>2</sup>	44 %	56 %	% m <sup>2</sup>	62 %	23 %	15 %	% m <sup>2</sup>	100 %			% m <sup>2</sup>	45 %	33 %	22 %	
<b>AH</b>		<b>AI</b>		<b>AJ</b>		<b>AK</b>									
Format	580x580	1160x290	Format	580x580	1160x145	Format	1160x290		Format	1160x290 - 870x290					
% m <sup>2</sup>	50 %	50 %	% m <sup>2</sup>	50 %	50 %	% m <sup>2</sup>	100 %		% m <sup>2</sup>	100 %					

100% Made in Spain

U MOUNTING SCHEME / ESQUEMA DE MONTAJE U  
/ SCHEMA DI MONTAGGIO U / U直拼

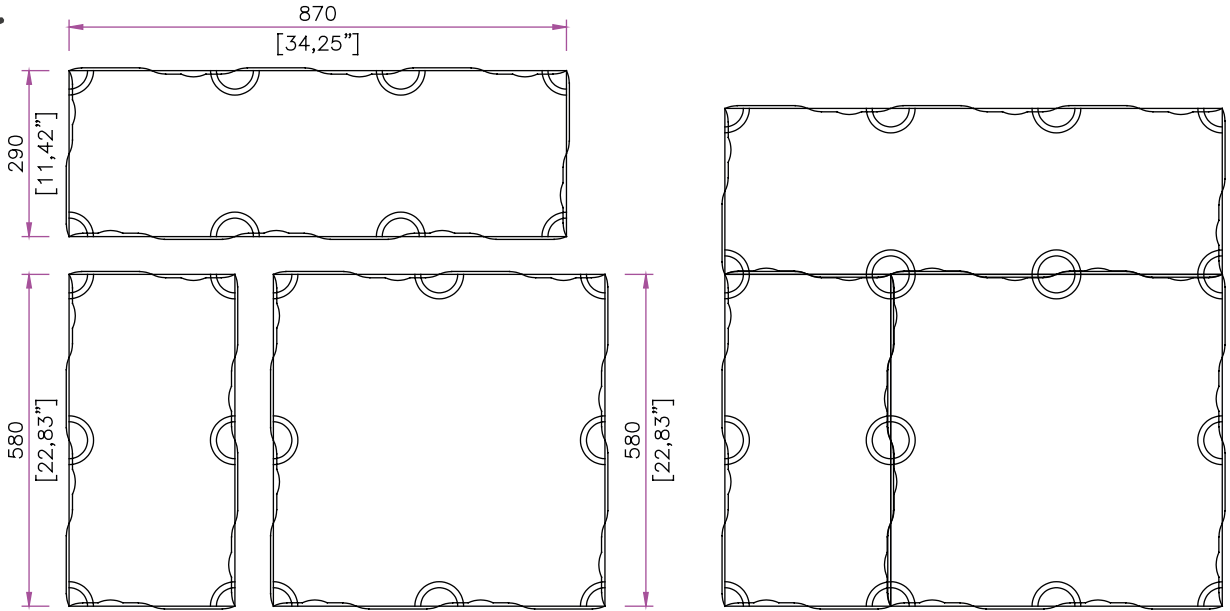

U1				U2				U3				U4			
Format	580x580	870x290	580x290	Format	580x580	870x290	580x290	Format	580x580	870x290	580x290	Format	580x580	870x290	580x290
% m <sup>2</sup>	45 %	33 %	22 %	% m <sup>2</sup>	45 %	33 %	22 %	% m <sup>2</sup>	45 %	33 %	22 %	% m <sup>2</sup>	45 %	33 %	22 %
U5				U6				U7				U8			
Format	580x580	870x290	580x290	Format	580x580	870x290	580x290	Format	580x580	870x290	580x290	Format	580x580	870x290	580x290
% m <sup>2</sup>	45 %	33 %	22 %	% m <sup>2</sup>	45 %	33 %	22 %	% m <sup>2</sup>	45 %	33 %	22 %	% m <sup>2</sup>	45 %	33 %	22 %

1160x290 - 870x290 - 580x290 VERSATILITY / VERSATILIDAD 1160x290 - 870x290 - 580x290 / VERSATILITÀ 1160x290 - 870x290 - 580x290 / 1160x290 - 870x290 - 580x290 多功能性



VERSATILE FORMATS, CAN BE LAID AS:

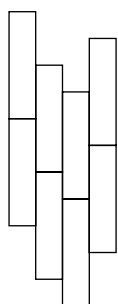

STRAIGHT PLANKS

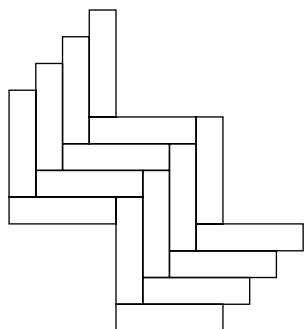

HERRINGBONE

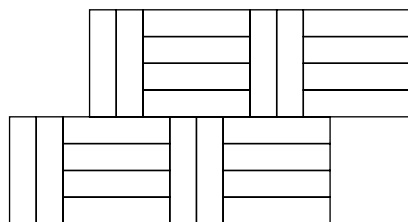

DIFFERENT FORMATS

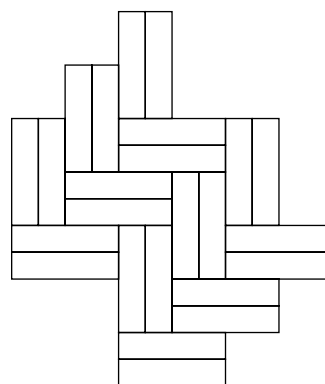

DOUBLE HERRINGBONE

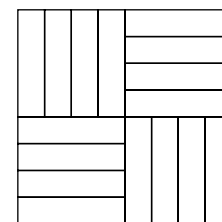

SQUARE

AF		H		AJ		AK		X	
Format	1160x290	Format	1160x290	Format	1160x290	Format	1160x290	Format	1160x290
AF		H		J		AK		X	
Format	870x290	Format	870x290	Format	870x290	Format	870x290	Format	870x290
I		H		K		E		F	
Format	580x290	Format	580x290	Format	580x290	Format	580x290	Format	580x290

100% Made in Spain

# MOUNTING SCHEMES

ESQUEMAS DE MONTAJE / SCHEMI DI MONTAGGIO / 安装方案



**W<sup>+</sup>** LISTONE<sup>®</sup>

**STANDARD FINISH**

CLASSIC

TRADITIONAL

**SPECIAL FINISH**

TRAFFIC

SHINE

LUX

HAND-SCRAPED

CROSS-CUT

**STANDARD**

TRAFFIC

**STANDARD**

TRAFFIC

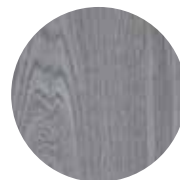
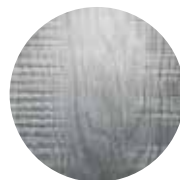
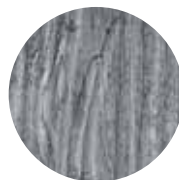
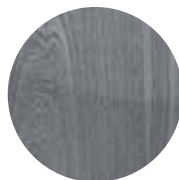

**HERRINGBONE ASSEMBLY SCHEME / ESQUEMA DE MONTAJE DE ESPIGA / SCHEMA DI MONTAGGIO A SPINA / 人字拼装配方案**



**ADVANTAGES**

- Just one piece for the whole pattern, A and B is avoided
- Reduce waste in at least -5%

**VENTAJAS**

- Sólo una pieza para todo el patrón, se evita A y B
- Se reduce el desperdicio en al menos un -5%

**VANTAGGI**

- Un solo pezzo per l'intero modello, si evita A e B
- Si riducono gli sprechi almeno un -5%

**优点**

- 整个图案只有一件，避免A和B
- 减少至少-5%的浪费

**580x145**

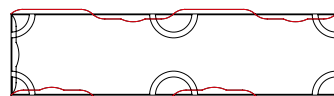

**STANDARD FORMAT**

**870x145**

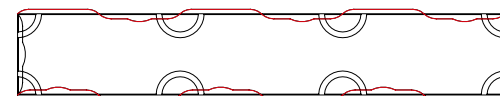

**STANDARD FORMAT**

**PARALLEL TONGUES**

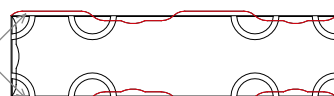

**HERRINGBONE FORMAT**



**HERRINGBONE FORMAT**

\*Herringbone also available in format 1160x145 / Herringbone también disponible en formato 1160x145 / Spina di pesce disponibile anche nel formato 1160x145 / Herringbone 还提供 1160x145 格式

**580x145**

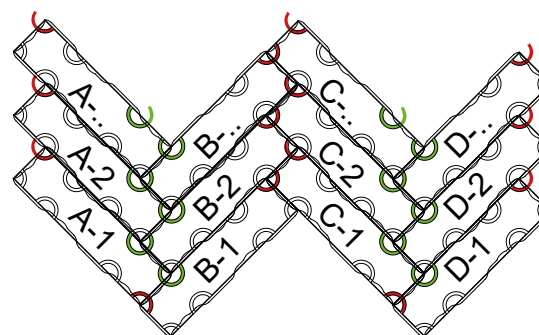
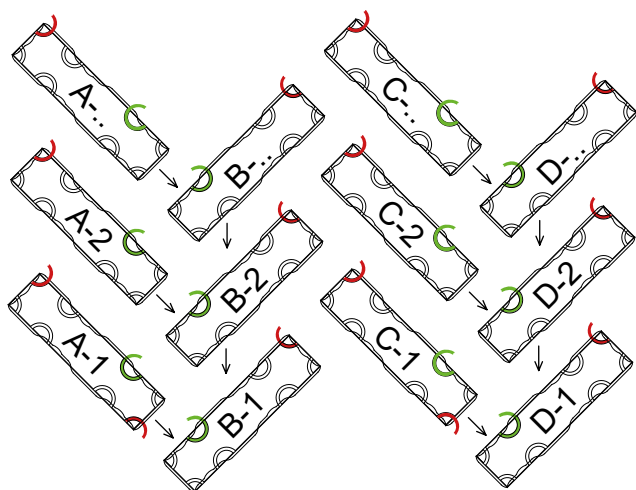

**870x145**

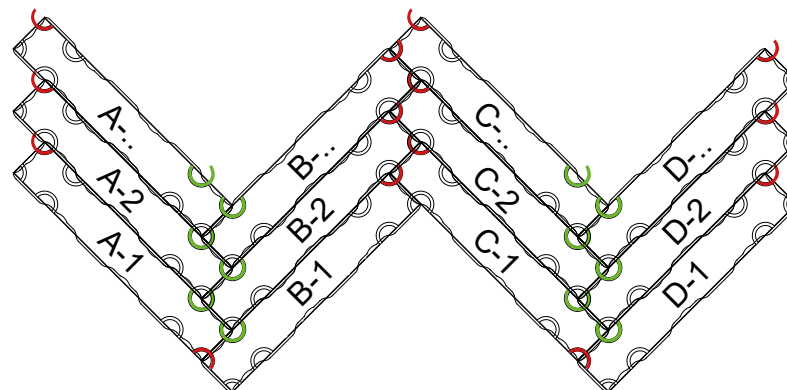
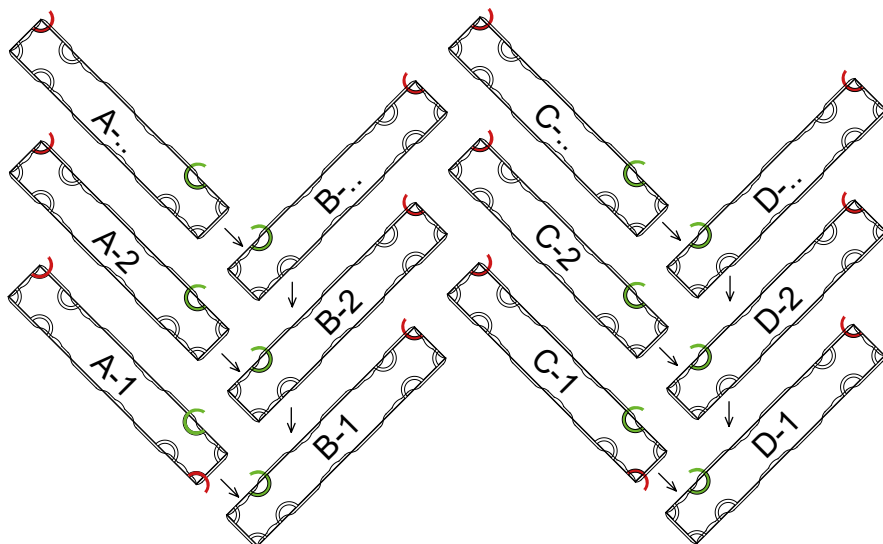

100% Made in Spain

# MOUNTING SCHEMES

ESQUEMAS DE MONTAJE / SCHEMI DI MONTAGGIO / 安装方案



 **Chevron**  
WOOD+ FLOORING

 **Fior Chevron**<sup>®</sup>

 **Wpk Chevron**<sup>®</sup>



STANDARD FINISH

CLASSIC

TRADITIONAL

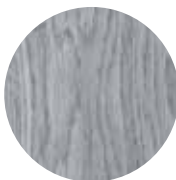

SPECIAL FINISH

TRAFFIC

SHINE

HAND-SCRAPED

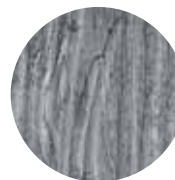
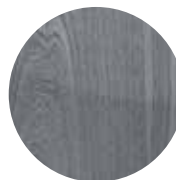

STANDARD

TRAFFIC

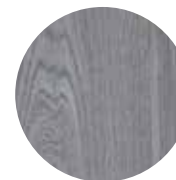

STANDARD

TRAFFIC

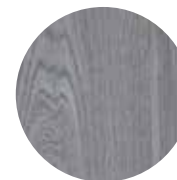



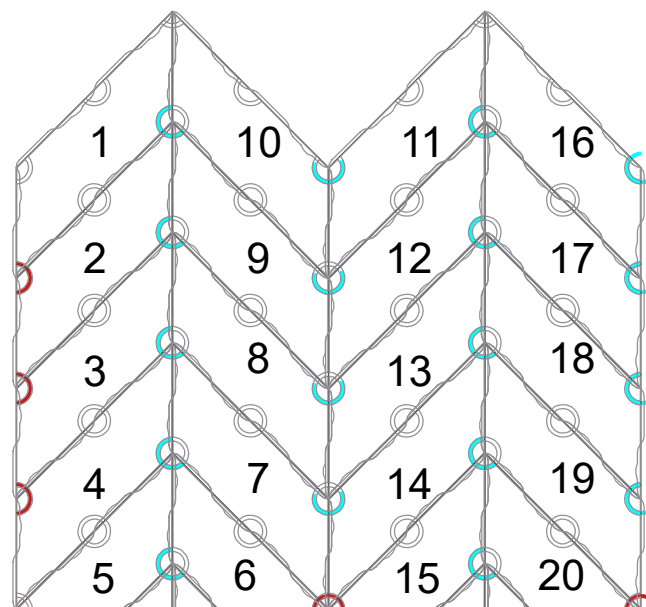
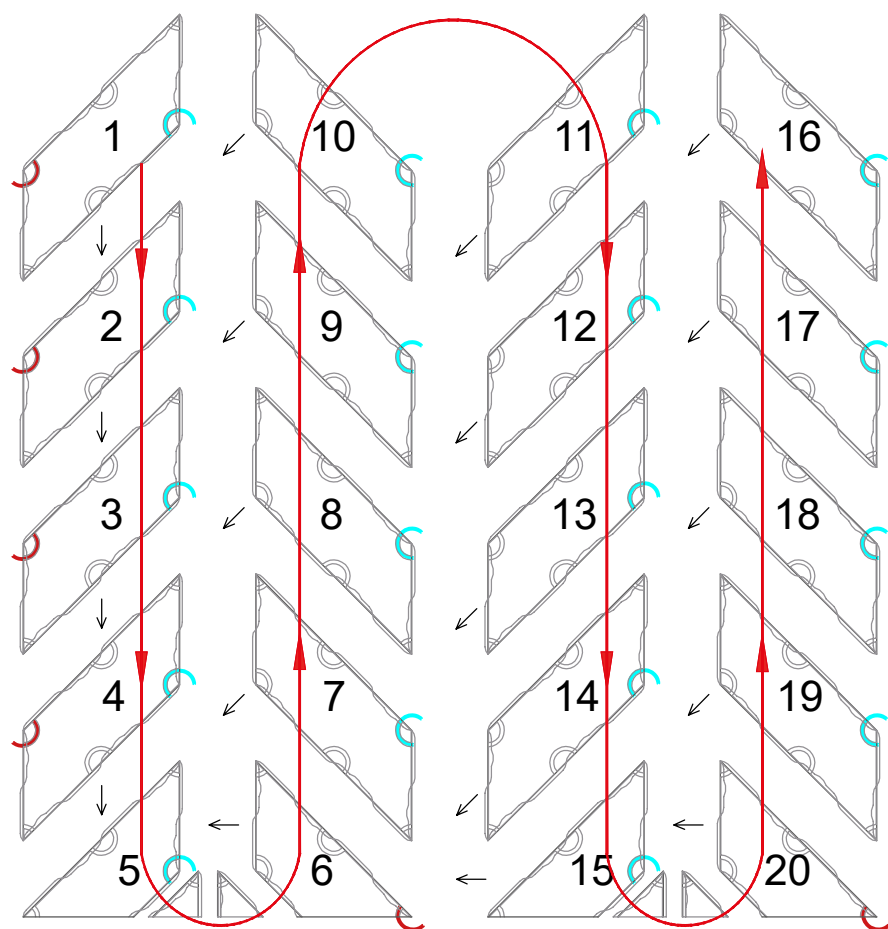





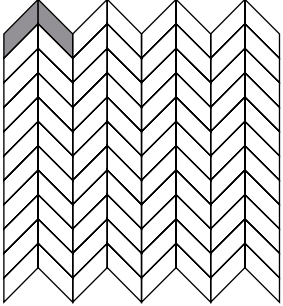
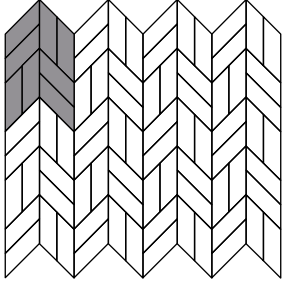
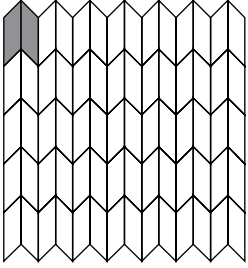
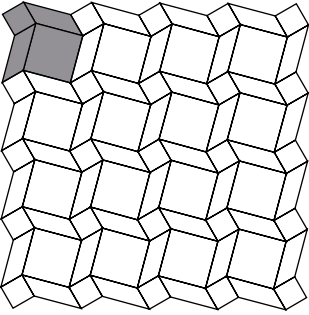
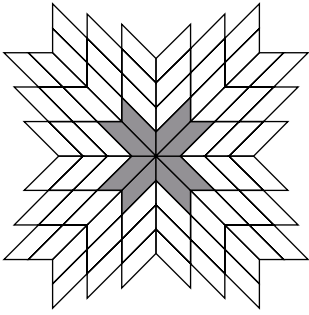
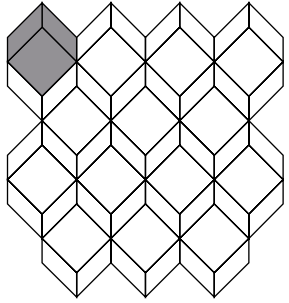
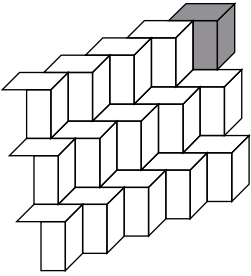
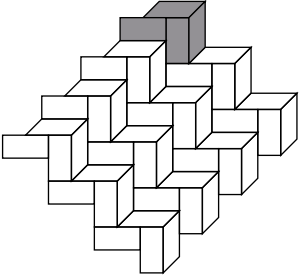
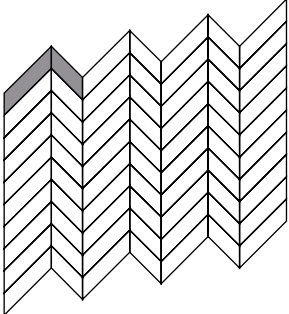



ASSEMBLY SCHEME / ESQUEMA DE MONTAJE  
/ SCHEMA DI MONTAGGIO / 装配图

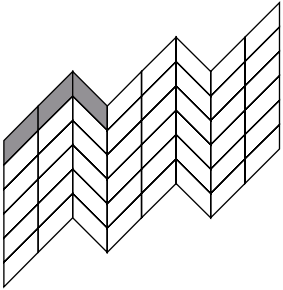
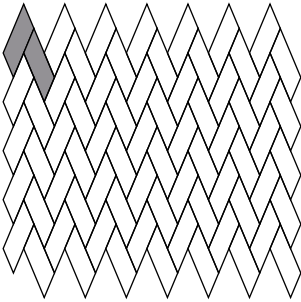
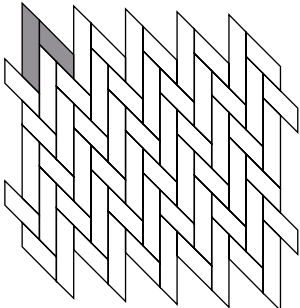

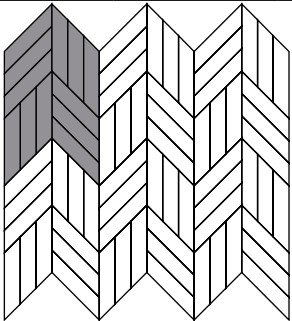
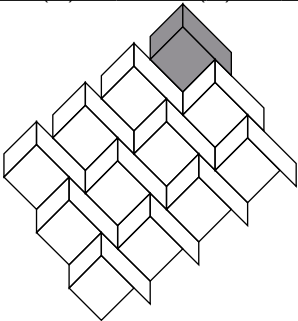
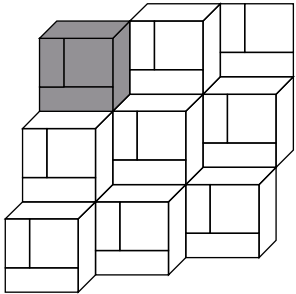

100% Made in Spain

CHV-A				CHV-B				CHV-C			
Format	870x205 A - 580x205 A - 870x145 A - 580x145 A - 410x145 A	870x205 B - 580x205 B - 870x145 B - 580x145 B - 410x145 B		Format	580x205 A - 410x145 A	580x205 B - 410x145 B		Format	870x205 A - 580x205 A - 870x145 A - 580x145 A - 410x145 A	870x205 B - 580x205 B - 870x145 B - 580x145 B - 410x145 B	
% m <sup>2</sup>	50 %		50 %	% m <sup>2</sup>	50 %		50 %	% m <sup>2</sup>	50 %		50 %
											
CHV-D				CHV-E				CHV-F			
Format	580x580	290x290	580x205B	Format	870x205 A - 580x205 A - 870x145 A - 580x145 A - 410x145 A	870x205 B - 580x205 B - 870x145 B - 580x145 B - 410x145 B		Format	580x580	580x205A - 580x145A	580x205B - 580x145B
% m <sup>2</sup>	51 %	13 %	36 %	% m <sup>2</sup>	50 %		50 %	% m <sup>2</sup>	58% (205) - 66% (145)	21% (205) - 17% (145)	21% (205) - 17% (145)
											
CHV-G				CHV-H				CHV-I			
Format	870x290 - 580x290	870/580x205A - 870/580x145A	870/580x205B - 870/580x145B	Format	870x290 - 580x290	870/580x205A - 870/580x145A	870/580x205B - 870/580x145B	Format	870x205A - 870x145A - 580x145A	580x205B - 580x145B - 410x145B	
% m <sup>2</sup>	42% (205) - 50% (145)	29% (205) - 25% (145)	29% (205) - 25% (145)	% m <sup>2</sup>	58% (205) - 66% (145)	21% (205) - 17% (145)	21% (205) - 17% (145)	% m <sup>2</sup>	60% (870) - 59% (580)	40% (580) - 41% (410)	
											

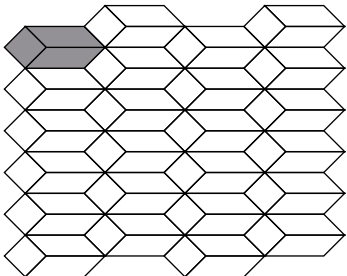
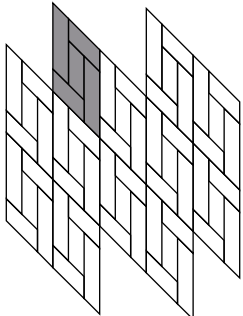
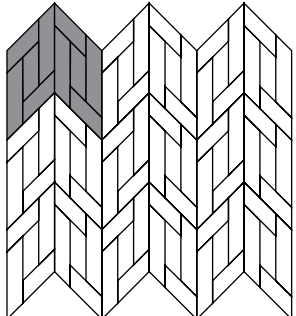
CHV-J 				CHV-K1 				CHV-K2 					
Format	870x205 A - 580x205 A - 870x145 A - 580x145 A - 410x145 A	870x205 B - 580x205 B - 870x145 B - 580x145 B - 410x145 B		Format	870x205A - 580x205A - 410x145A	870x205B - 580x205B - 410x145B		Format	870x205A	580x205B			
% m <sup>2</sup>	67 %	33 %		% m <sup>2</sup>	50 %	50 %		% m <sup>2</sup>	60 %	40 %			
													
CHV-L 				CHV-M 				CHV-N 					
Format	870x205A	870x205B		Format	580x580	580x205A - 580x145A	870x205B - 870x145B	Format	870x290	580x580	580x290	870x205A - 870x145A	870x205B - 870x145B
% m <sup>2</sup>	50 %	50 %		% m <sup>2</sup>	53% (205) - 62% (145)	19% (205) - 15% (145)	28% (205) - 23% (145)	% m <sup>2</sup>	23% (205) - 25% (145)	30% (205) - 34% (145)	15% (205) - 17% (145)	16% (205) - 12% (145)	16% (205) - 12% (145)
													
CHV-O 				CHV-P 				CHV-Q 					
Format	290x290	870x205A - 580x205A	870x205B - 580x205B	Format	870x205A	580x205A	580x205B	Format	870x205A	870x205B	580x205A	580x205B	
% m <sup>2</sup>	20% (870) - 26% (580)	40% (870) - 37% (580)	40% (870) - 37% (580)	% m <sup>2</sup>	50 %	17 %	33 %	% m <sup>2</sup>	25 %	25 %	25 %	25 %	
													

100% Made in Spain

# MOUNTING SCHEMES

ESQUEMAS DE MONTAJE / SCHEMI DI MONTAGGIO / 安装方案













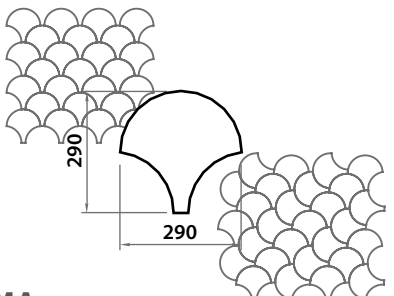

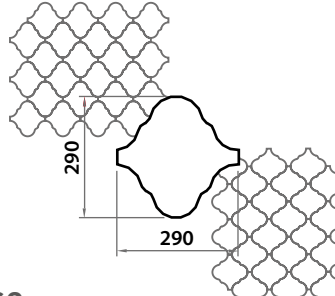

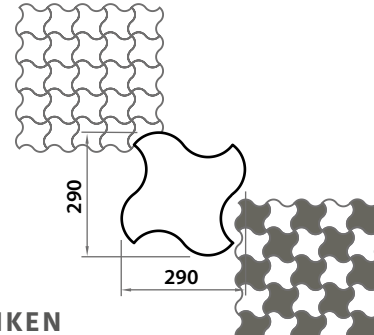
■ **W<sup>+</sup> DESIGN<sup>®</sup>**

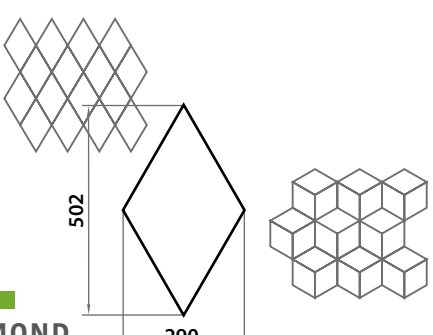
■ **Fior DESIGN<sup>®</sup>**

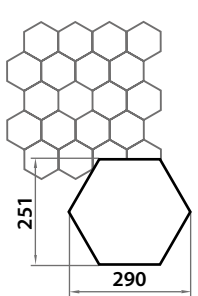
■ **Wpk DESIGN<sup>®</sup>**

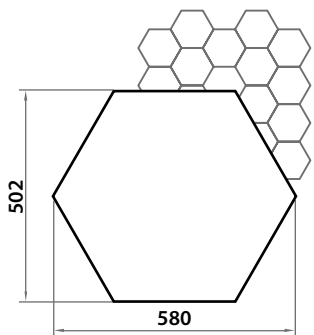
\*Check availability of finishes according to format. Consultar disponibilidad de acabados según formato. Verifica la disponibilità delle finiture in base al formato. 根据规格确认表面处理工艺的可用性

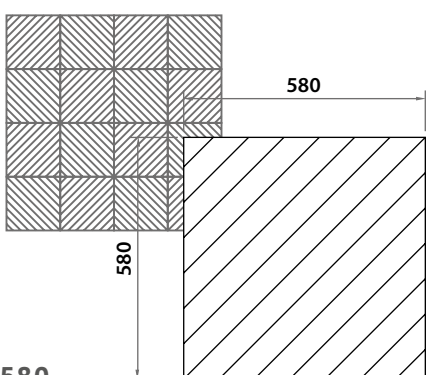
STANDARD FINISH		SPECIAL FINISH					STANDARD	STANDARD
CLASSIC	TRADITIONAL	TRAFFIC	SHINE	LUX	HAND-SCRAPED	CROSS-CUT	TRAFFIC	TRAFFIC
								

 <p>    <b>SQUAMA</b>  <b>290x290</b>  <b>11,42"x11,42"</b> </p>	 <p>    <b>MORISCO</b>  <b>290x290</b>  <b>11,42"x11,42"</b> </p>	 <p>    <b>SHURIKEN</b>  <b>290x290</b>  <b>11,42"x11,42"</b> </p>
 <p>    <b>DIAMOND</b>  <b>502x290</b>  <b>19,77"x11,42"</b> </p>	 <p>    <b>HEXAGON 290</b>  <b>290x251</b>  <b>11,42"x9,88"</b> </p>	 <p>    <b>HEXAGON 580</b>  <b>580x502</b>  <b>22,83"x19,76"</b> </p>
 <p>    <b>45G</b>  <b>580x580</b>  <b>22,83"x22,83"</b> </p>		

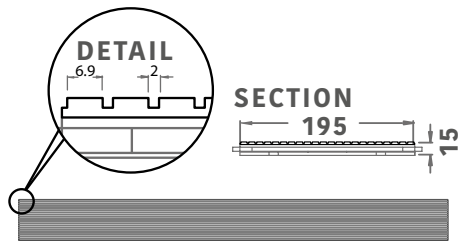

■  
**MULTI-RIGATO**  
2030x195  
79,92"x7,68"

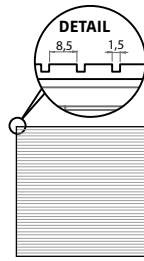

■ ■ ■  
**MULTI-RIGATO**  
580x580  
22,83"x22,83"

\*Pattern only suitable for wall covering  
/ Diseño solo apto para revestimiento  
de pared / Modello adatto solo per  
rivestimento a parete / 图案仅适用于墙布

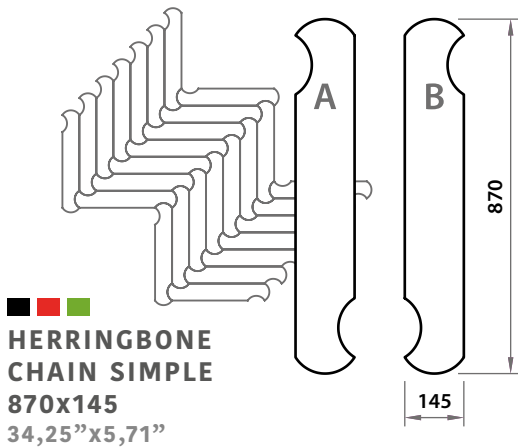
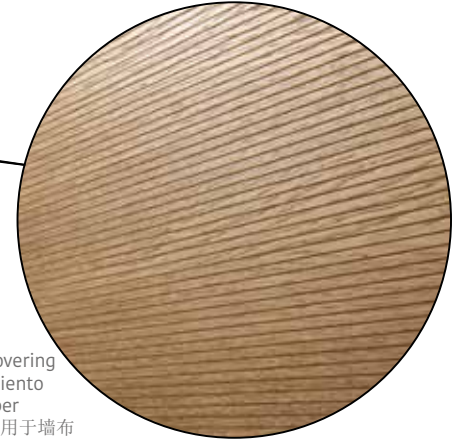

■ ■ ■  
**HERRINGBONE  
CHAIN SIMPLE**  
870x145  
34,25"x5,71"

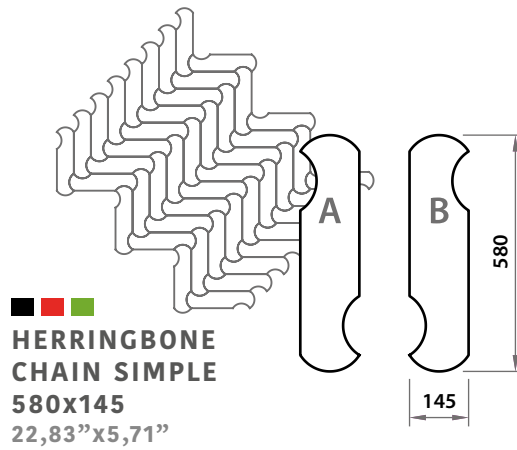

■ ■ ■  
**HERRINGBONE  
CHAIN SIMPLE**  
580x145  
22,83"x5,71"

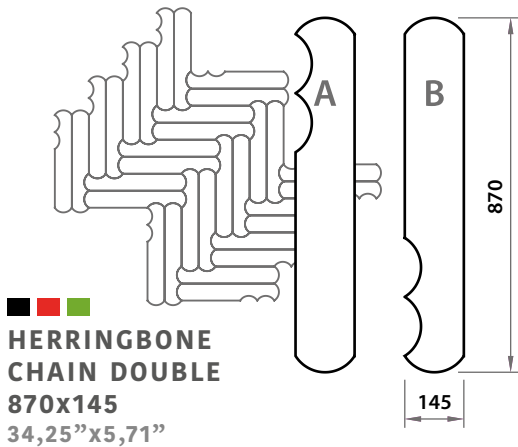

■ ■ ■  
**HERRINGBONE  
CHAIN DOUBLE**  
870x145  
34,25"x5,71"

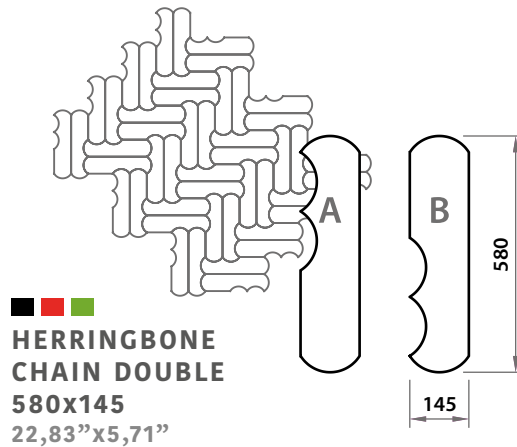

■ ■ ■  
**HERRINGBONE  
CHAIN DOUBLE**  
580x145  
22,83"x5,71"

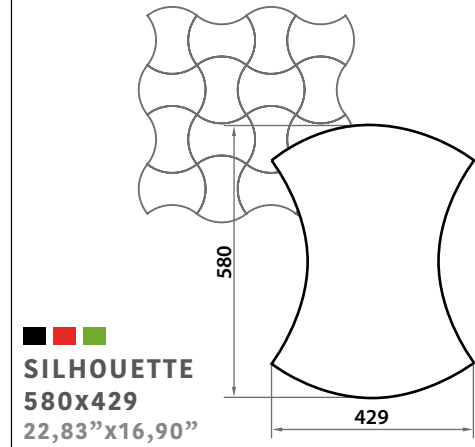

■ ■ ■  
**SILHOUETTE**  
580x429  
22,83"x16,90"

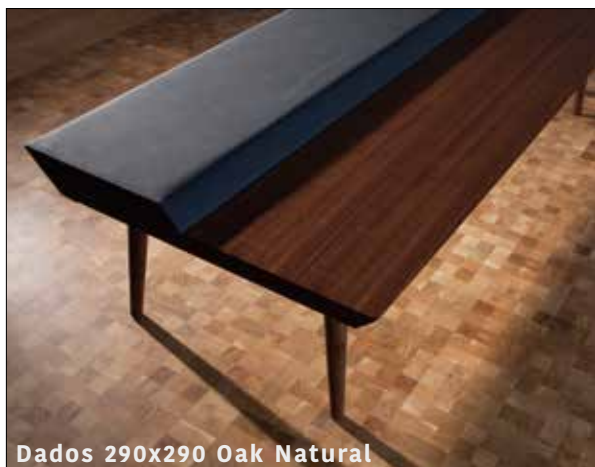

Dados 290x290 Oak Natural

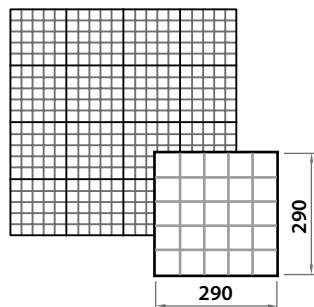

**DADOS**  
**290x290**  
**11,42"x11,42"**



OAK  
**NATURAL**



AMERICAN  
WALNUT  
**NATURAL**

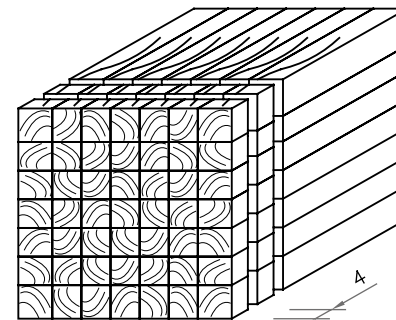

End Grain Cutting / Cortado a testa /  
Legno di testa / 端面晶粒切割

Only for glued down installation / Solo para  
colocación encolada / Solo per posa incollata  
/ 只用胶合安装

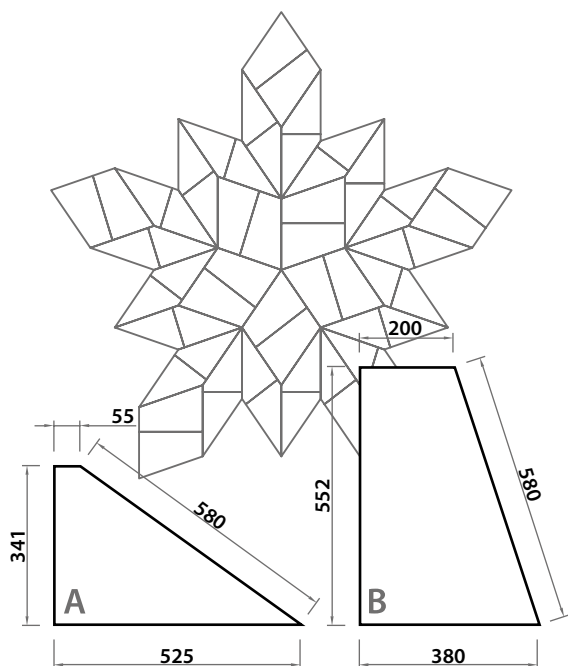

**LINK 580 A**  
**525x341**  
**20,67"x13,43"**

**LINK 580 B**  
**380x552**  
**14,96"x21,73"**

100% Made in Spain

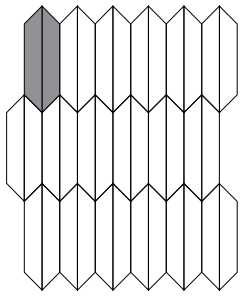
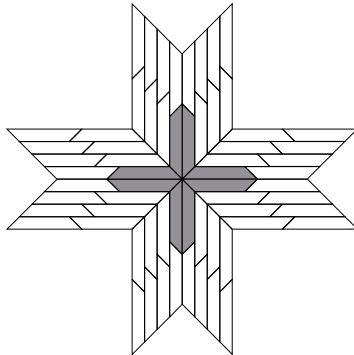
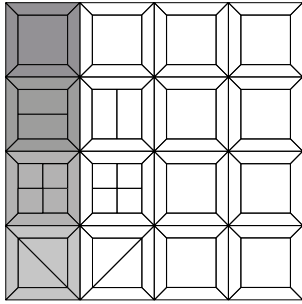
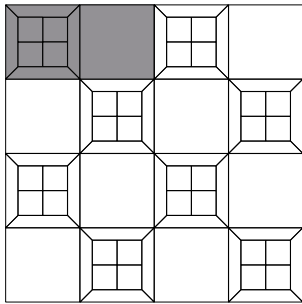
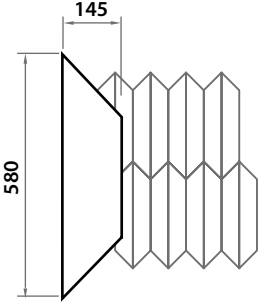
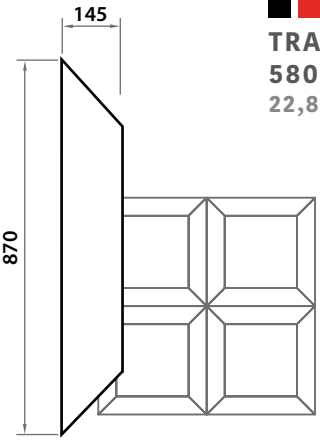
TRP-A		TRP-B	
Format	TRAPEZIUM 870x145 - TRAPEZIUM 580x145	Format	TRAPEZIUM 870x145 - TRAPEZIUM 580x145
% m <sup>2</sup>	100 %	% m <sup>2</sup>	100 %
			
TRP-C		TRP-D	
Format	TRAPEZIUM 870 - TRAPEZIUM 580	580x580 (- 580x290 - 290x290 - TRG 580x580) - 290x290	
% m <sup>2</sup>	56% (870) - 75% (580)	44% (870) - 25% (580)	
			
 <p><b>TRAPEZIUM 580</b> <b>580x145</b> 22,83"x5,71"</p>		 <p><b>TRAPEZIUM 870</b> <b>870x145</b> 34,25"x5,71"</p>	



Braid 615x410 - 580x145 Oak Aged

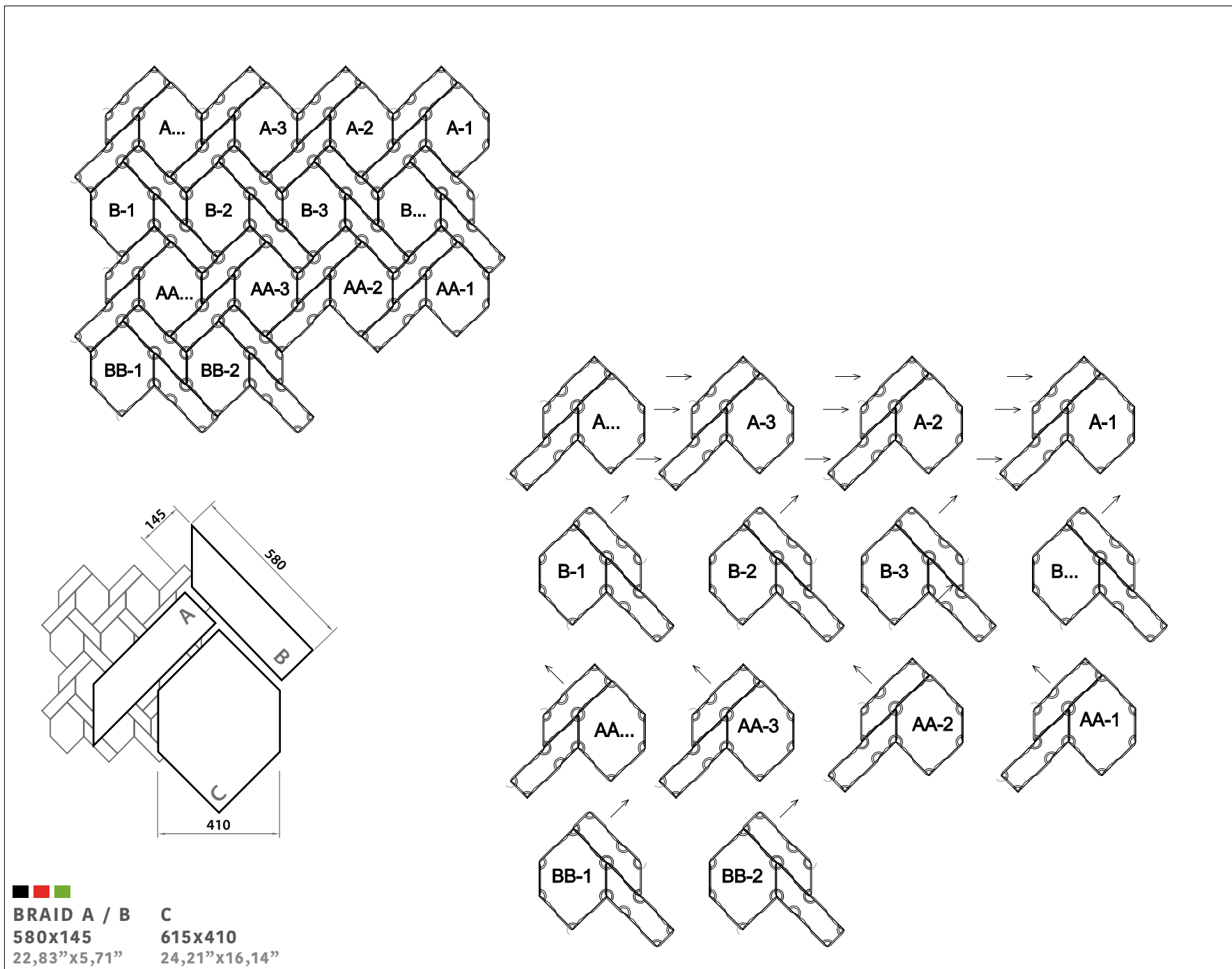



100% Made in Spain

TRG-A		TRG-B	
Format	TRIANGLE 580x580	Format	TRIANGLE 580x580
% m <sup>2</sup>	100 % (50% of each color)	% m <sup>2</sup>	100 % (50% of each color)

TRG-C		TRG-D	
Format	TRIANGLE 580x580	Format	TRIANGLE 580x580
% m <sup>2</sup>	100 % (50% of each color)	% m <sup>2</sup>	100 % (50% of each color)

TRG-E		
Format	TRIANGLE 580x580	580x580
% m <sup>2</sup>	50 % (25% of each color)	50 %

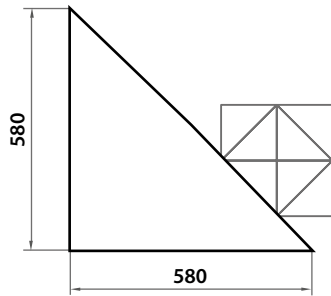

**TRIANGLE**  
**580x580**  
 22,83" x 22,83"



Triangle 580x580  
Oak Extra White - Oak Limestone



100% Made in Spain



Looping 8 2030x230 Oak Naturalizzato

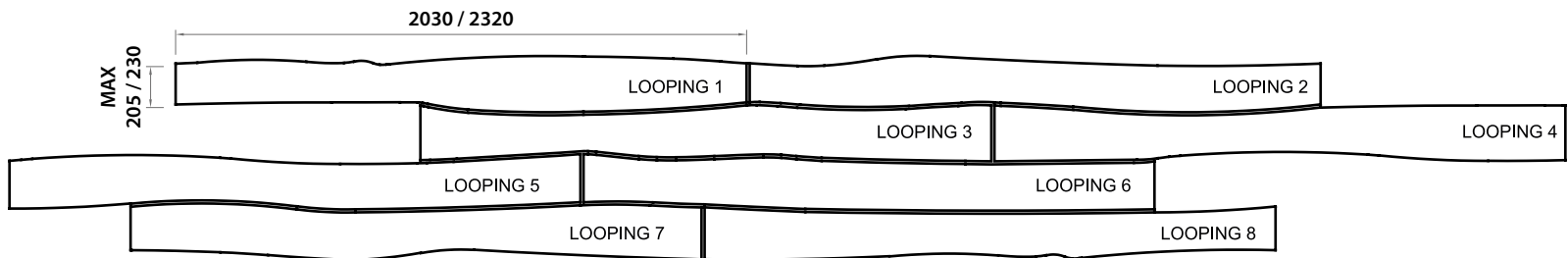

■ **LOOPING 8<sup>1</sup>**  
**2030x230**  
 79,92”x9,06”

■ **LOOPING 8<sup>1</sup>**  
**2030x205**  
 79,92”x8,07”

■ ■ **LOOPING 8**  
**2320x230**  
 91,34”x9,06”

\* 8 different pieces. STANDARD: Regular bevel. <sup>1</sup>Width option (205/230) subject to availability, quantity and color.  
 \* 8 piezas distintas. ESTÁNDAR: Bisel regular. <sup>1</sup>Opción de ancho (205/230) sujeto a disponibilidad, cantidad y color.  
 \* 8 pezzi diversi. STANDARD: Bisello regolare. <sup>1</sup>Opzione larghezza (205/230) soggetta a disponibilità, quantità e colore.  
 \* 八个不同的木块：标准、常规倒角、<sup>1</sup>宽度选项（205/230）视供应情况、数量和颜色而定。

# LOOPING

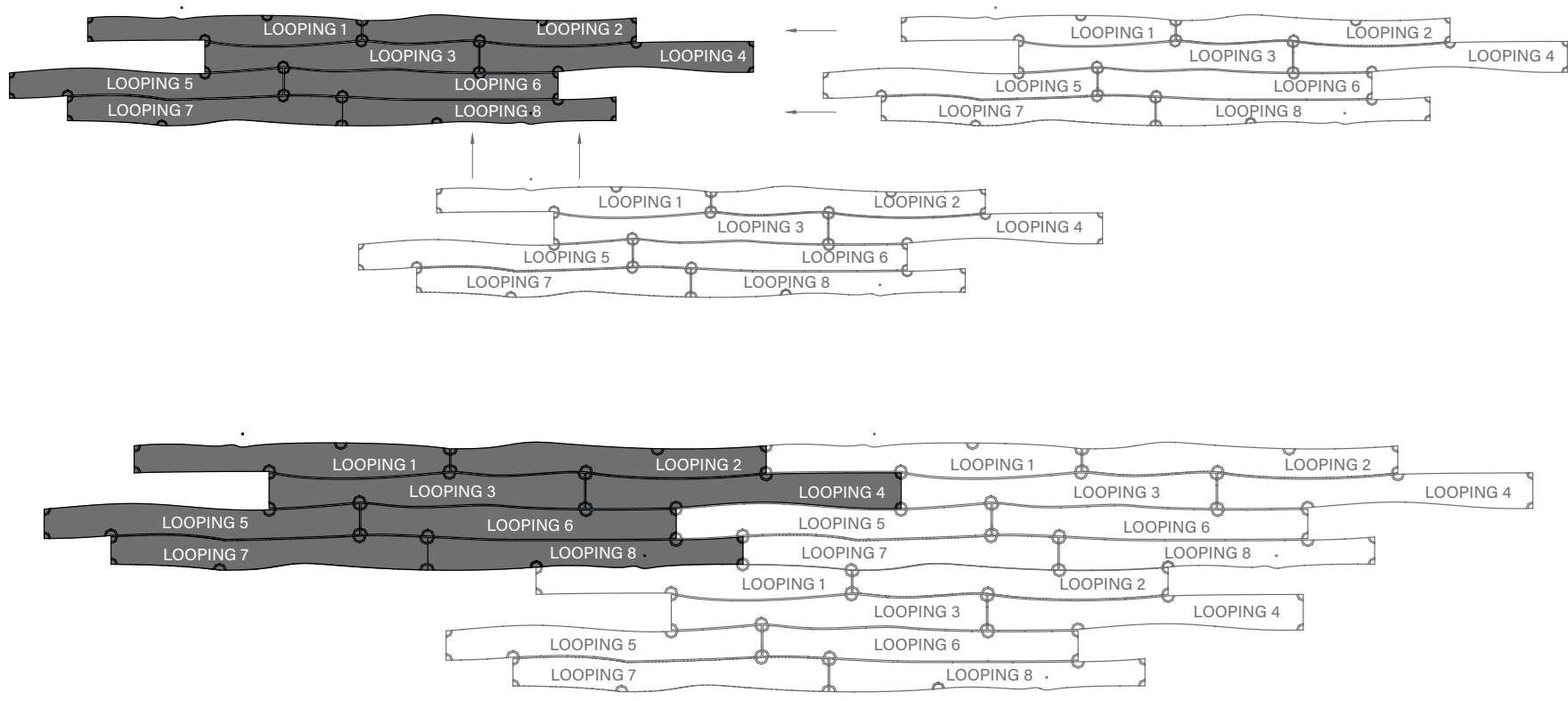

100% Made in Spain



**RHOMBUS**

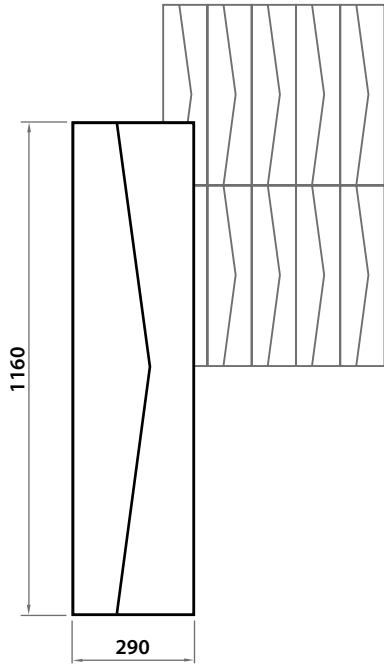

■  
**RHOMBUS**  
**1160x290**  
 45,67”x11,42”

One unique piece composed of 2 different portions of **3 mm of noble wood**, with different grain direction, and a core of **12 mm of 100% birch plywood**. Engineered with **LockSTP system**, for floating installation, also able to be glued down  
 Nominal thickness of **15 mm**



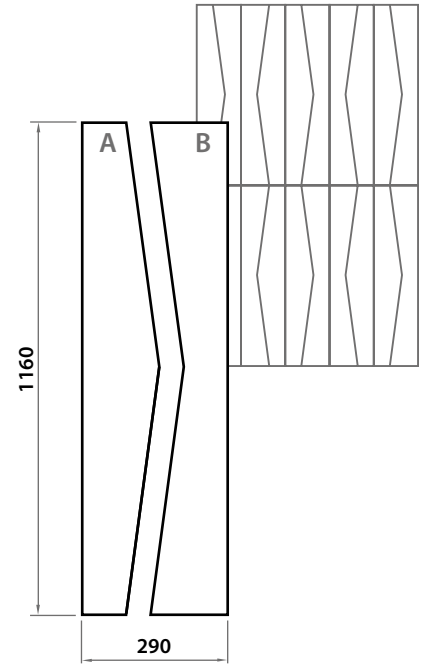



**RHOMBUS 10**

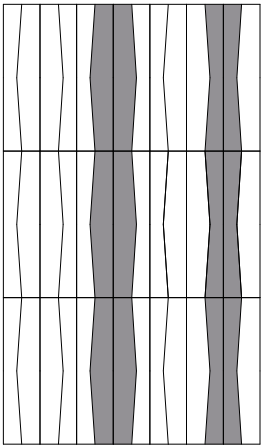
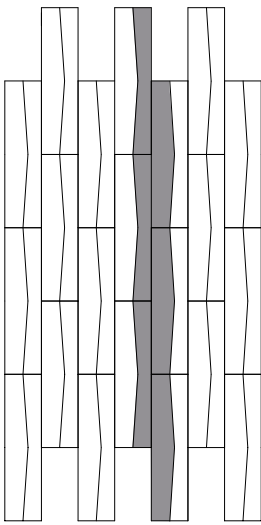
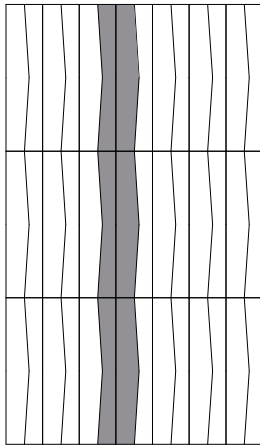

■ ■  
**RHOMBUS A / B**  
**1160x290**  
 45,67”x11,42”

Pattern composed of 2 different pieces (A & B), each one composed of a full piece of **0,6 mm** on the top layer of **noble wood**, **9 mm** on the core of **100% birch plywood** or **HDF (density>900kg/3)**, and a contra-balance layer at the backside of **0,6 mm of wood veneer** with a finishing coat of varnish for extra stability and fire resistance. Both pieces engineered with **LockSTP system**, for floating installation, also able to be glued down  
 Nominal thickness of **10 mm**

Rhombus 1160x290 Oak Stone (Cross-cut)

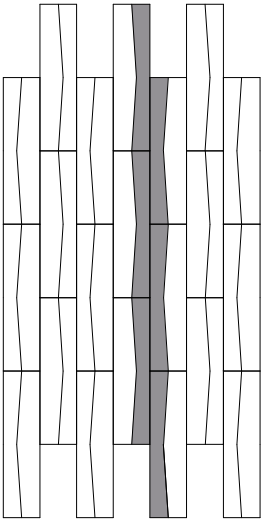
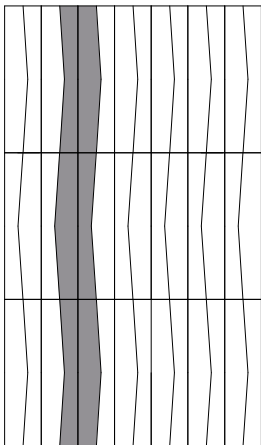
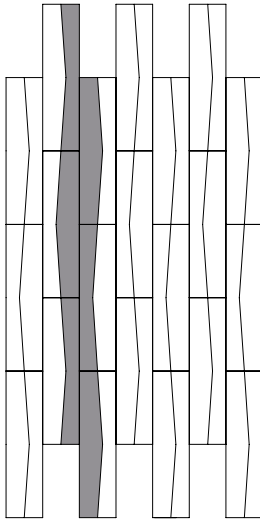
<b>RHM-A</b> 		<b>RHM-B</b> 		<b>RHM-C</b> 	
Format	RHOMBUS 1160x290	Format	RHOMBUS 1160x290	Format	RHOMBUS 1160x290
% m <sup>2</sup>	100 %	% m <sup>2</sup>	100 %	% m <sup>2</sup>	100 %
					
<b>RHM-D</b> 		<b>RHM-E</b> 		<b>RHM-F</b> 	
Format	RHOMBUS 1160x290	Format	RHOMBUS 1160x290	Format	RHOMBUS 1160x290
% m <sup>2</sup>	100 %	% m <sup>2</sup>	100 %	% m <sup>2</sup>	100 %
					

**TRENCADIS**  
**1160x580**  
 45,67"x22,83"

6 COMPLETELY DIFFERENT PIECES

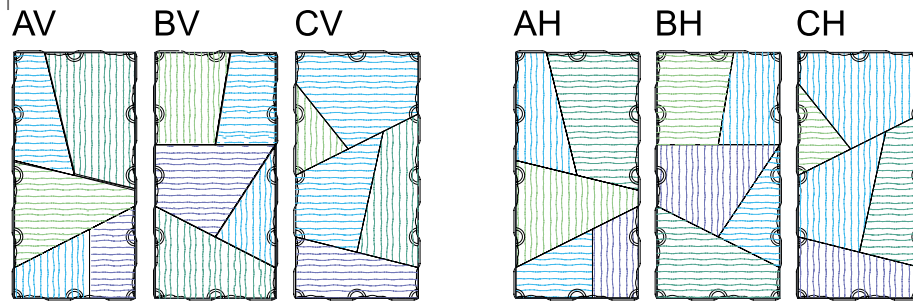

3 different designs with different grain direction for each portion of each piece, 2 variations for each design, with opposite grain direction, Vertical & Horizontal

3 different designs with different grain direction for each portion of each piece, 2 variations for each design, with opposite grain direction, Vertical & Horizontal



**TRENCADIS 10**  
**1160x580**  
 45,67"x22,83"

6 COMPLETELY DIFFERENT PIECES

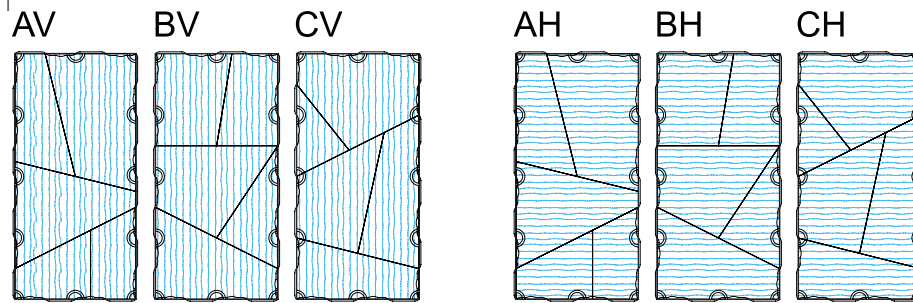

3 different designs but with the same vertical grain direction for each full piece, 2 variations for each design, with opposite grain direction, Vertical & Horizontal

3 different designs but with the same horizontal grain direction for each full piece, 2 variations for each design, with opposite grain direction, Vertical & Horizontal



**TRENCADIS 16**  
**1160x580**  
 45,67"x22,83"

6 COMPLETELY DIFFERENT PIECES

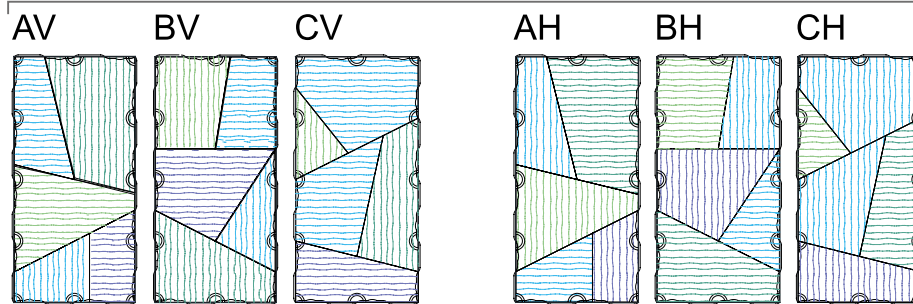

3 different designs with different grain direction for each portion of each piece, 2 variations for each design, with opposite grain direction, Vertical & Horizontal

3 different designs with different grain direction for each portion of each piece, 2 variations for each design, with opposite grain direction, Vertical & Horizontal



TRENCADIS		TRENCADIS 10		TRENCADIS 16	
3 different designs (and 2 variations for each design, with opposite grain direction, Vertical & Horizontal = 6 completely different pieces) composed of 5 different portions of <b>3 mm of noble wood</b> , with different grain direction		3 different designs (2 variations for each design, V & H = 6 different pieces) engineered on a full piece composed of		3 different designs (2 variations for each design, V & H = 6 different pieces) composed of 5 different portions of	
Core of <b>12 mm of 100% birch plywood</b>		0,6 mm on the top layer of <b>noble wood</b> , with the same grain direction		0,6 mm on the top layer of <b>noble wood</b> , with different grain direction	
		9 mm on the core of <b>100% birch plywood</b>	9 mm on the core of <b>HDF</b> (density>900kg/3)	9 mm on the core of <b>100% birch plywood</b>	9 mm on the core of <b>HDF</b> (density>900kg/3)
		0,6 mm of <b>wood veneer</b> with a finishing coat of varnish for extra stability and fire resistance		0,6 mm of <b>wood veneer</b> with a finishing coat of varnish for extra stability and fire resistance	
		Base of <b>6 mm of 100% birch plywood</b>			
All engineered with <b>LockSTP system</b> , for floating installation, also able to be glued down					
Nominal thickness of <b>15 mm</b>		Nominal thickness of <b>10 mm</b>		Nominal thickness of <b>16 mm</b>	
<b>TRN-A</b> ■ ■ ■		<b>TRN-B</b> ■ ■ ■		<b>TRN-C</b> ■ ■ ■	
Format	TRENCADIS 1160x580	Format	TRENCADIS 1160x580	Format	TRENCADIS 1160x580
% m <sup>2</sup>	100 %	% m <sup>2</sup>	100 %	% m <sup>2</sup>	100 %
<b>TRN-D</b> ■ ■ ■		<b>TRN-E</b> ■ ■ ■		<b>TRN-F*</b> ■ ■ ■	
Format	TRENCADIS 1160x580	Format	TRENCADIS 1160x580	Format	TRENCADIS 1160x580
% m <sup>2</sup>	100 %	% m <sup>2</sup>	100 %	% m <sup>2</sup>	100 %
				*Most recommended pattern	



100% Made in Spain

# TECHNICAL INFORMATION

INFORMACION TECNICA / INFORMAZIONI TECNICHE / 技术信息

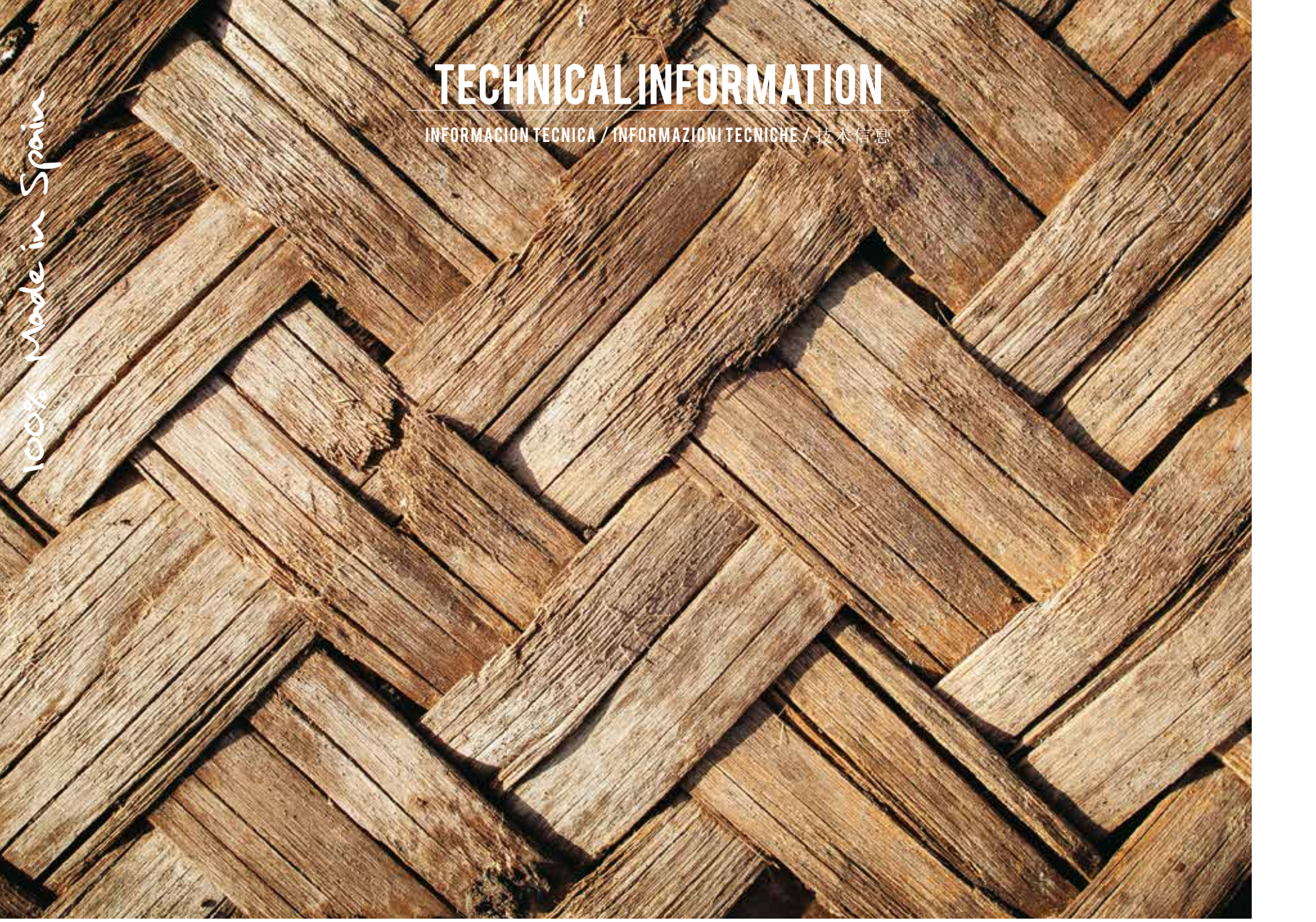

STANDARD FINISH

CLASSIC

TRADITIONAL



SPECIAL FINISH

TRAFFIC

SHINE

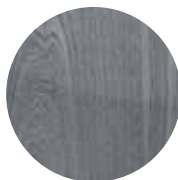

STANDARD

TRAFFIC



STANDARD

TRAFFIC





Different portions of <b>3 mm of noble wood</b> , with different grain direction	Different portions of	<b>0,6 mm</b> on the top layer of <b>noble wood</b> , with different grain direction	Different portions of	<b>0,6 mm</b> on the top layer of <b>noble wood</b> , with different grain direction	
		<b>9 mm</b> on the core of <b>100% birch plywood</b>		<b>9 mm</b> on the core of <b>HDF</b> (High Density Fiberboard, density>900kg/3)	
		<b>0,6 mm</b> of wood veneer with a finishing coat of varnish for extra stability and fire resistance		<b>0,6 mm</b> of wood veneer with a finishing coat of varnish for extra stability and fire resistance	
Core of <b>12 mm of 100% birch plywood</b>	Base of <b>6 mm of 100% birch plywood</b>	Base of <b>6 mm of 100% birch plywood</b>	All engineered with <b>LockSTP system</b> , for floating installation, also able to be glued down		
Nominal thickness of <b>15 mm</b>	Nominal thickness of <b>16 mm</b>	Nominal thickness of <b>16 mm</b>			

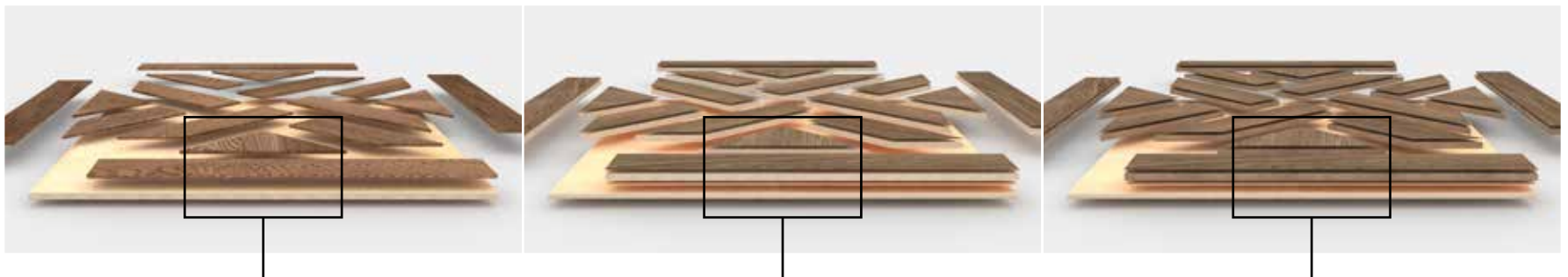

100% Made in Spain

# TECHNICAL INFORMATION

INFORMACION TECNICA / INFORMAZIONI TECNICHE / 技术信息



■ Wood Mosaic®  
DÉCO STYLE

FINISH

TRAFFIC



# STRUCTURE

ESTRUCTURA / STRUTTURA / 结构

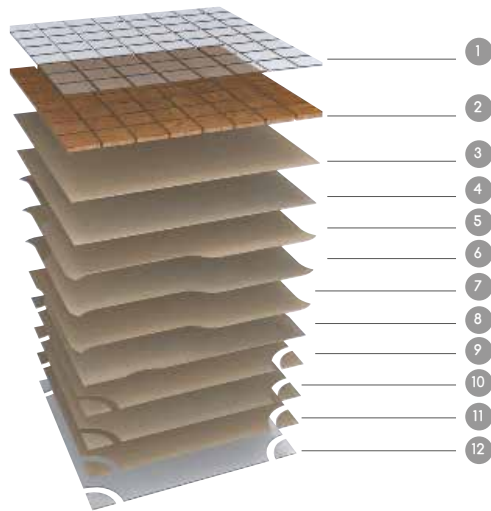

## ENG

- 1 1st overlay STP Traffic. High-performance protective overlay consisting of up to 12 coats combining stained, primer, and protective varnish, to give the product a resistant finish and create an oil effect at the same time. Gloss 15.
- 2 1st layer. Noble wood of 3/4 mm thickness (depending on collection and finish), micro-beveled on all four sides.
- 3 (3-11) Central Layer. Composed of 9 alternating layers of 100% birch plywood that works as an internal shaft and gives to the whole structure greater strength and stability (Thickness 12mm / 0.47").
- 4 2nd overlay. Waterproofing varnish. Made of a layer of pore-filler varnish which helps to ensure the compact plan configuration of the piece.

## ESP

- 1 1a aplicación STP Traffic. Capa protectora de alto rendimiento compuesta por hasta 12 aplicaciones que combinan tinte, imprimación y barniz protector, para dar al producto un acabado resistente y crear un efecto aceite al mismo tiempo. Gloss 15.
- 2 1a capa. Madera noble de 3/4 mm de espesor (según colección y acabado), micro-biselada en los cuatro lados.
- 3 (3-11) Capa central. Compuesta por 9 capas alternas de contrachapado 100% abedul que funciona como eje interno y le da a toda la estructura una mayor resistencia y estabilidad (Espesor 12mm / 0.47").
- 4 2a aplicación. Barniz impermeabilizante. Compuesto por una capa de barniz tapa poros que contribuye a garantizar la planimetría de la pieza.

## IT

- 1 1a applicazione STP Classic. Pellicola protettiva ad alte prestazioni composta da un massimo di 12 mani che combinano vernice per la colorazione, primer e vernice protettiva, per conferire al prodotto una finitura resistente e creare allo stesso tempo un effetto olio.
- 2 1o strato. Legno nobile di 3/4 mm spessore (a seconda della collezione e della finitura), micro-biselato sui quattro lati.
- 3 (3-11) Strato centrale. Composto da 9 strati alternati di multistrato di betulla 100% che hanno la funzione controbilanciante e conferisce a tutta la struttura maggiore resistenza e stabilità (Spessore 12mm / 0.47").
- 4 2a applicazione. Vernice impermeabilizzante. Costituita da un strato di vernice per la chiusura dei pori che contribuisce a garantire la planarità del materiale.

## CN

- 1 经典保护层：由多达12层的着色、底漆和保护清漆组成的高性能保护层，给产品一个耐磨保护涂层，同时创造一个油的效果。
- 2 第一层：3/4毫米名贵实木层（取决于优异的选材和表面加工），四边微倒角处理。
- 3 中间层（3-11）：由9层100%全桦木基材，纵横交错组成，使得整体结构超强坚韧及稳定（12mm厚度）。
- 4 底层：防水漆面处理。由一层孔隙填料清漆制成，有助于确保地板紧凑的平面配置。

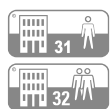

# MOSAIC INSTALLATION METHOD

METODO DE INSTALACION DEL MOSAICO / METODO DI INSTALLAZIONE DEL MOSAICO / 马赛克地板 - 马赛克地板安装方法

## ENG

### INSTALLING THE MOSAIC

Either the adhesive-free LockSTP system or adhesives can be used to install mosaics on vertical surfaces. If using the adhesive installation method, STP recommends using EUROPOSA.

### GROUTING THE MOSAIC

STP recommends using STP POXI\* for grouting. STP POXI is an easy-to-clean, high-performance acid proof three-component epoxy sealant.

Use only on a dry, clean surface. Apply the product using a suitable rubber spatula. Performing circular movements wash the surface with a damp cloth while the product is still wet, then clean with a stiff sponge for a smooth, sealed surface.

### TECHNICAL FEATURES

The product will give maximum performance after 24 hours. For further information visit our website.

## ESP

### COLOCACIÓN DEL MOSAICO

Para fijar el mosaico en superficies verticales, puede servirse del sistema sin cola LockSTP, u optar por la adhesión química. Si opta por la adhesión química, STP aconseja el uso de EUROPOSA como mejor mortero de pegado.

### REJUNTADO DEL MOSAICO

STP aconseja el uso de STP POXI\* como mejor mortero de rejunte. Se trata de un mortero epoxídico antiácido tricomponente de extraordinarias prestaciones y gran facilidad de limpieza. Utilizar siempre sobre soportes limpios y secos. Aplicar y trabajar siempre el producto con una espátula de goma adecuada. Limpiar el producto cuando aún está fresco ayudándose de abundante agua y una esponja de fieltro blanco, realizando movimientos circulares, y terminar con una esponja rígida para obtener una superficie lisa y cerrada.

### CARACTERÍSTICAS TÉCNICAS

El producto alcanza las máximas prestaciones pasadas 24 horas. Para más información consulte el envase o visite nuestra página web.

## IT

### COLLOCAZIONE DEL MOSAICO

Per posare il mosaico in superfici verticali, può essere utilizzato il sistema senza colla LockSTP, oppure si può optare per l'utilizzo di collanti. Se si sceglie l'utilizzo di collanti, STP consiglia l'uso di EUROPOSA come prodotto ideale.

### STUCCATURA DEL MOSAICO

STP consiglia l'uso di STP POXI\* come prodotto ideale per le fughe. STP POXI è un sigillante epossidico antiacido tricomponente ad elevate prestazioni e di facile pulizia.

Utilizzare sempre sulla superficie pulita e asciutta. Applicare il prodotto con una spatola di gomma adatta. Lavare quando il prodotto è ancora fresco, utilizzare spugne in feltro bianco inumidito, eseguendo movimenti circolari, successivamente pulire con spugna rigida per ottenere una superficie liscia e chiusa.

### CARATTERISTICHE TECNICHE

Il prodotto raggiunge le sue massime prestazioni dopo 24 ore. Per maggiori informazioni visitare il nostro sito.

## CN

### 安装马赛克地板

LOCKSTP无胶锁扣安装，和传统胶水安装，均适用于马赛克地板的安装

### 马赛克地板填缝

STP推荐用STP POXI\*给马赛克地板填缝。STP POXI是一种三组份环氧填缝剂，易清洁，抗氧化腐蚀。

只能在干燥、干净的表面使用。使用提供的特殊橡胶刮刀涂抹产品。当产品还是湿的时候，用湿布做圆周运动清洗表面，然后用硬海绵清洁表面，使产品表面光滑、密封。

### 技术特点

该产品在24小时后将发挥最大的性能。更多信息请访问我们的网站。

Mortar for sealing acid-resistant joints, from 0 to 10 mm. Low viscosity. Easy application. Mortero para el sellado de juntas ácido-resistentes, de 0 a 10 mm. Baja viscosidad. Fácil aplicación. Stucco per sigillatura di fughe acidoresistenti, da 0 a 10 mm. Bassa viscosità. Facile applicazione. 填缝剂用于密封接缝，使缝隙抗氧化耐腐蚀，从0到10mm。低粘度。简单应用。

## COLORS

COLORS / COLORES / COLORI / 花色

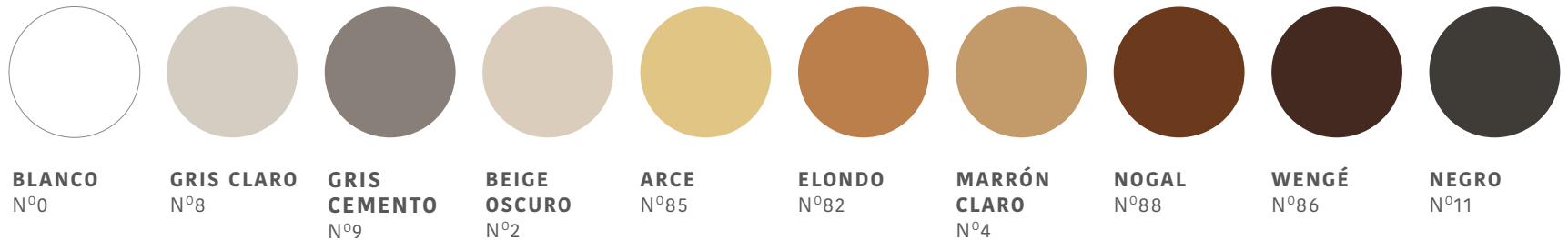

### ENG

STP POXI is a three-component compound made using selected silica sand, stable pigments, and special additives which harden through a simple chemical reaction. Resulting in an exceptional product for:

- Optimal chemical resistance to detergents, corrosive acids, etc
- High mechanical resistance.
- Totally impermeable: 100%.

Please note that,

- STP POXI is not an expansion joint.
- Do not use the grouting material on wet, dirty, or dusty tiles.
- Take special care in cleaning sealing materials without varnishing.
- Do not make half and half mixes. Mix the total quantity of the three components.
- Do not add any other component to the STP POXI which could modify its characteristics.

### ESP

STP POXI es un compuesto tricomponente elaborado con arenas silíceas seleccionadas, pigmentos estables y aditivos especiales, que se endurecen mediante una simple reacción química, dando como resultado un producto excepcional para:

- Óptima resistencia química a detergentes, ácidos corrosivos,...
- Elevadas resistencias mecánicas.
- Total impermeabilidad: 100%.

A tener en cuenta,

- STP POXI no son juntas de dilatación.
- No usar el material de rejuntado en piezas mojadas, sucias, llenas de polvo,...
- Tener especial precaución en la limpieza, cuando se rejuntan materiales sin barnizar.
- No realizar mezclas parciales. Mezclar los tres componentes por completo.
- No añadir ningún otro componente al STP POXI que pudiera modificar sus características.

### IT

STP POXI è un composto tricomponente a base di sabbie silicee selezionate, pigmenti stabili e additivi speciali, che induriscono semplicemente per reazione chimica, garantendo un prodotto eccezionale per:

- Ottima resistenza chimica a detergenti, acidi corrosivi, ecc...
- Elevate resistenze meccaniche.
- Totale impermeabilità: 100%.

Avere in considerazione,

- STP POXI non è indicato per i giunti di dilatazione.
- Non utilizzare il materiale di sigillatura delle fughe su mosaici bagnati, sporchi, coperti di polvere, ecc...
- Realizzare una pulizia particolarmente accurata qualora si esegua la sigillatura di fughe su materiali non verniciati.
- Non eseguire impasti parziali. Impastare tutta la quantità in dotazione dei tre componenti.
- Non aggiungere a STP POXI nessun altro componente che possa alterarne le caratteristiche.

### CN

STP POXI填缝剂是一种三组分化合物，由精选的硅砂、稳定的颜料和特殊添加剂制成，通过简单的化学反应固化。其特点为：

- 耐腐蚀、抗氧化
- 超强耐磨
- 100%防水

但请注意：







- STP POXI填缝剂没有伸缩缝作用
- 不要在潮湿、肮脏或尘土飞扬的产品表面使用填缝剂
- 在清洗填缝剂时要特别小心，不要给填缝剂染上颜色
- 不要部分混合三组份，要将这三种成分全部混合在一起使用
- 不要添加任何其他成分，否则会改变填缝剂的性能

# ACCESSORIES

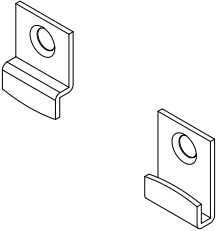
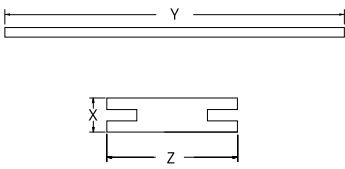
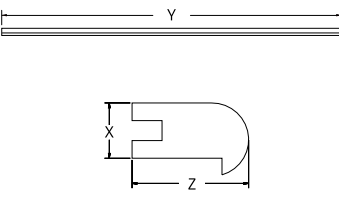
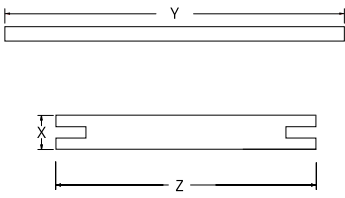
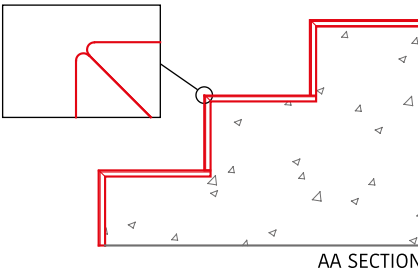
ACCESORIOS / ACCESSORI / 配件

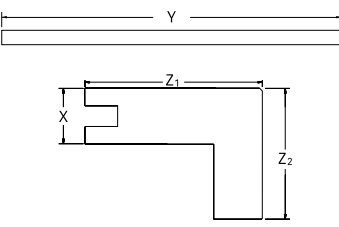
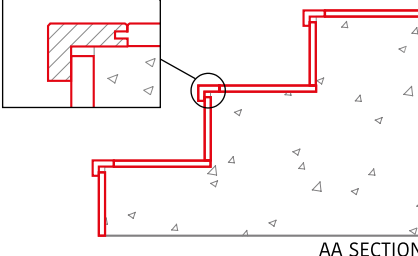

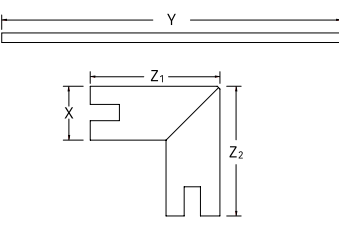
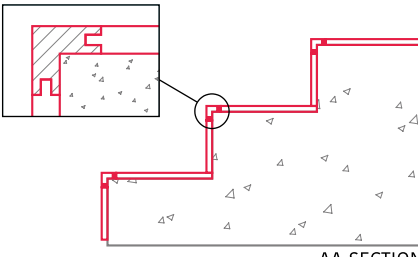
ACCESSORIES ACCESORIOS ACCESSORI 配件		MEASURES MEDIDAS MISURE 測量	ACCESSORIES ACCESORIOS ACCESSORI 配件		MEASURES MEDIDAS MISURE 測量
SKIRTING ZÓCALO BATTISCOPIA 踢脚线 (5 pieces/box / 5 piezas/caja / 5 pezzi/scatola / 五个一盒)		X x Y x Z <ul style="list-style-type: none"> <li>■ 15x2400x80mm 0,59"x94,49"x3,15"</li> <li>■ 15x2400x80mm 0,59"x94,49"x3,15"</li> <li>■ 15x2400x80mm 0,59"x94,49"x3,15"</li> </ul>	Edge cover inox Perfil cubrecorte inox Profilo copritaglio inox 不锈钢边缘覆盖		X x Y x Z <ul style="list-style-type: none"> <li>■ 15x2000x18mm 0,59"x78,74"x0,71"</li> <li>■ 10x2000x18mm 0,39"x78,74"x0,71"</li> <li>■ 10x2000x18mm 0,39"x78,74"x0,71"</li> </ul>
Auction perimeter Remate perimetral Profilo di chiusura perimetrale 预装板材 (*For wall installation / *Para instalación en pared / *Per posa a parete / *适用于墙壁安装)		X x Y x Z <ul style="list-style-type: none"> <li>■ 15x2400x40mm 0,59"x94,49"x1,57"</li> <li>■ 10x2400x40mm 0,39"x94,49"x1,57"</li> <li>■ 10x2400x40mm 0,39"x94,49"x1,57"</li> </ul>	Auction perimeter inox Remate perimetral inox Profilo di chiusura perimetrale inox 不锈钢边界周长		X x Y x Z <ul style="list-style-type: none"> <li>■ 18x2000x13mm 0,71"x78,74"x0,51"</li> <li>■ 13x2000x13mm 0,51"x78,74"x0,51"</li> <li>■ 13x2000x13mm 0,51"x78,74"x0,51"</li> </ul>
Landing perimeter Remate desnivel Soglia di raccordo 地触 (*For floor installation / *Para instalación en suelos / *Per posa in suolo / *适用于地板安装)		X x Y x Z <ul style="list-style-type: none"> <li>■ 15x2400x29mm 0,59"x94,49"x1,14"</li> <li>■ 10x2400x32mm 0,39"x94,49"x1,26"</li> <li>■ 10x2400x32mm 0,39"x94,49"x1,26"</li> </ul>	Landing perimeter inox Remate desnivel inox Soglia di raccordo inox 不锈钢地触		X x Y x Z <ul style="list-style-type: none"> <li>■ 18x2000x25mm 0,71"x78,74"x0,98"</li> <li>■ 13x2000x19mm 0,51"x78,74"x0,75"</li> <li>■ 13x2000x19mm 0,51"x78,74"x0,75"</li> </ul>
Board dilatation Junta dilatación Giunto di dilatazione 伸缩缝		X x Y x Z <ul style="list-style-type: none"> <li>■ 15x1160x145mm 0,59"x45,67"x5,71"</li> <li>■ 10x1160x145mm 0,39"x45,67"x5,71"</li> <li>■ 10x1160x145mm 0,39"x45,67"x5,71"</li> </ul>	<p>USE OF THE BOARD DILATATION / USO DE JUNTAS DE DILATACIÓN / USO DELLA GIUNTE DI DILATAZIONE / 使用董事会扩张:</p> <ul style="list-style-type: none"> <li>• Transitions between different formats and patterns.</li> <li>• Transition in doors, as a doorsill.</li> <li>• Large surfaces. We consider a large surface, dimensions about 10 meters length and 8 meters width, approximately.</li> <li>• Transition between two different colors. In this case the joint is a half of each color.</li> <li>• Transiciones entre distintos formatos y patrones de montaje.</li> <li>• Transición en puertas.</li> <li>• Grandes superficies. Entendemos como grande superficie dimensiones de aproximadamente 10 metros de largo y 8 metros de ancho.</li> <li>• Transición entre dos colores distintos. En este caso la junta es una mitad de cada color.</li> <li>• Transizioni tra diversi formati e modelli.</li> <li>• Transizione nelle porte, come davanzale.</li> <li>• Grandi superfici. Consideriamo una superficie ampia, delle dimensioni di circa 10 metri di lunghezza e 8 metri di larghezza, circa.</li> <li>• Transizione tra due colori diversi. In questo caso la giuntura è la metà di ogni colore.</li> <li>• 不同格式和模式之间的过渡。</li> <li>• 门内的过渡，作为门槛。</li> <li>• 大表面。我们考虑一个大表面，尺寸约为长 10 米、宽 8 米。</li> <li>• 两种不同颜色之间的过渡。在这种情况下，关节是每种颜色的一半。</li> </ul>		

<b>ACCESSORIES</b> <b>ACCESORIOS</b> <b>ACCESSORI</b> 配件		<b>MEASURES</b> <b>MEDIDAS</b> <b>MISURE</b> 测量	<b>ACCESSORIES</b> <b>ACCESORIOS</b> <b>ACCESSORI</b> 配件		<b>MEASURES</b> <b>MEDIDAS</b> <b>MISURE</b> 测量
Covering hook "H" Enganche revestimiento "H" Clips rivestimento "H" 覆盖勾"H" Covering Hook "L" Enganche revestimiento "L" Clips rivestimento "L" 覆盖勾"L"		$X \times Y \times Z_H / Z_L$ ■ 7x15x25/18mm 0,28"x0,59"x0,98/0,7" ■ 5x15x25/18mm 0,2"x0,59"x0,98/0,7" ■ 5x15x25/18mm 0,2"x0,59"x0,98/0,7"	Strip perimeter 40 Faja perimetral 40 Fascia perimetrale 40 条状周长40		$X \times Y \times Z$ ■ 15x2400x40mm 0,59"x94,49"x1,57" ■ 10x2400x40mm 0,39"x94,49"x1,57" ■ 10x2400x40mm 0,39"x94,49"x1,57"
Bullnose for treads Remate peldaño Toro per pedata 外圆角踏板		$X \times Y \times Z$ ■ 15x2400x80mm 0,59"x94,49"x3,15" (*Valid just for specific projects / Válido sólo para proyectos específicos / Valido solo per progetti specifici / 仅对特定项目有效)	Strip perimeter 80 Faja perimetral 80 Fascia perimetrale 80 条状周长80		$X \times Y \times Z$ ■ 15x2400x80mm 0,59"x94,49"x3,15" ■ 10x2400x80mm 0,39"x94,49"x3,15" ■ 10x2400x80mm 0,39"x94,49"x3,15"
<b>STANDARD STAIRS</b> <b>ESTANDAR ESCALERAS</b> <b>STANDARD SCALE</b> 标准楼梯					
Custom step mitered at 45° Peldaño hecho a medida a inglete a 45° Gradino su misura smussato a 45° 定制台阶 45° 斜接	No accessory required for this option No se requieren accesorios para esta opción Nessun accessorio richiesto per questa opzione 此选项不需要任何配件		PROFILE DETAIL 		
Square edge for treads Remate peldaño recto Toro per pedata dritto 方形边缘的踏板		$X \times Y \times Z_1 \times Z_2$ ■ 15x2400x55x40mm 0,59"x94,49"x2,17"x1,57" ■ 10x2400x55x40mm 0,39"x94,49"x2,17"x1,57" ■ 10x2400x55x40mm 0,39"x94,49"x2,17"x1,57"	PROFILE DETAIL 		
Angled auction perimeter Cantonera Profilo di chiusura perimetrale angolare 直角边界周长		$X \times Y \times Z_1 \times Z_2$ ■ 15x2400x40x40mm 0,59"x94,49"x1,57"x1,57" ■ 10x2400x40x40mm 0,39"x94,49"x1,57"x1,57" ■ 10x2400x40x40mm 0,39"x94,49"x1,57"x1,57"	PROFILE DETAIL 		



# SILENT UNDERLAY

**LOCKSTP**<sup>®</sup>  
EXCELLENT GLUELESS SYSTEM

Patent-protected  
worldwide



26 dB



150 KPa

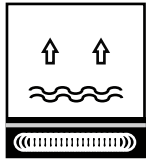

0.058 m<sup>2</sup>/k/W

PROPERTY	STANDARD	UNIT	VALUE
Dimension	-	m / inches	12.50 x 1.20 / 41'-0.13" x 3'-11.24"
Area	-	m <sup>2</sup> / sq.ft.	15 / 161.5
Caliber	ASTM D3767	mm	3.0
Density	DIN53420	Kg/m <sup>3</sup>	250
Fire Classification	EN ISO 13501	3mm	B <sub>FL-S1</sub>
Compressive Strength	DIN EN 826:2013	KPa	150
Impact Sound	ISO 10140-3:2010 ASTM E492-E989	Db Class: IIC	26 62
Reverb Sound	ISO 140/B ASTM E413-10 STC	%dBA dBA	23 55
Water Vapour resistance factor	DIN-56215	-	850
Water absorption	ASTM D570	-	None
Thermal Conductivity	DIN-52612	w/m.k	0.036
Thermal Resistance	ASTMC-177	(m <sup>2</sup> ·k)/W	0.058
Slip Resistance Dynamic Coef. of Friction	EN 14041:2004 EN 13893:2002	X Direction Y Direction	0.61 0.61
Formaldehyde emission	EN 14041:2006 Clause 4.3 and EN 717	mg/m <sup>3</sup>	ND Class E1

Recycled rubber (vinyl acetate, crosslinked and expanded by compression), manufactured and specially designed for the preservation and care of parquet and veneered floors. Anti-bacterial and impermeable material of non-porous closed cell. Excellent acoustic insulation, does not store electromagnetic charges. The HDPE sheet provides additional protection against moisture, for the general compliance of prescribed salubrity in the basic document HS of health of the CTE.

Caucho reciclado (acetato de vinilo, reticulado y expandido por compresión), fabricado y diseñado especialmente para la conservación y cuidado de parquet y suelos enchapados. Material antibacteriano e impermeable de celda cerrada no porosa. Excelente aislamiento acústico, no almacena cargas electromagnéticas. La lámina de HDPE le confiere una protección adicional frente a la humedad, para el cumplimiento general de la salubridad prescrita en el documento básico HS de salud del CTE.

Gomma riciclata (acetato di vinile, reticolato ed espanso per compressione), prodotta e appositamente progettata per la conservazione e la cura del parquet e dei pavimenti impiallacciati. Materiale antibatterico e impermeabile a cellule chiuse non porose. Ottimo isolamento acústico, non accumula cariche elettromagnetiche. Il foglio in HDPE conferisce una protezione aggiuntiva contro l'umidità, per il rispetto generale dei requisiti di salubrità prescritti nel documento base HS di sanità dell'ETC.

再生橡膠（醋酸乙烯酯，透過壓縮交聯和膨脹），專為保護和護理鑲木地板和單板地板而製造和設計。無孔閉孔抗菌防滲材料。隔音性能優良，不儲存電磁電荷。HDPE 片材為其提供額外的防潮保護，整體符合 CTE 健康基本文件 HS 中規定的健康性。

STP SILENT UNDERLAY is a closed-cell polyolefin foam specially developed and designed as an acoustic underlay for wooden and laminate flooring.

#### INSTALLATION:

In order to install the layer, the floor must be stable, without level differences, and completely dry (<=2...3 M-% according to CM method). If the unevenness level exceeds 2 mm/m, the floor must be leveled previously. If the flooring was fitted carpet, linoleum, parquet, or any other organic material, it must be removed before starting the installation.

Remove any object from the floor, and start stretching the isolating layer progressively, as we install the parquet, with the printed side upwards.

Stretch the layer so that it doesn't crease, and join the sides by the film overlap with a suitable ca. 50 mm wide PP or PVC based adhesive tape.

STP SILENT UNDERLAY es una espuma de poliolefina de célula cerrada especialmente desarrollada y diseñada para uso como manta acústica en la colocación de pavimento de madera y laminado.

#### INSTALACIÓN:

Para realizar la instalación, se requiere un suelo estable, sin desniveles y completamente seco (<=2...3 m-% según método CM). Si la superficie tiene una falta de planitud superior a los 2 mm/m, ésta debe ser nivelada previamente.

En caso de que el suelo preexistente esté formado por moqueta, linóleo, parquet o cualquier otro material orgánico, es necesario arrancarlo.

Retirar cualquier elemento extraño del firme y extender la manta aislante, a medida que realice la instalación, quedando la cara impresa a la vista.

Evitar la formación de pliegues, y unir las entre sí solapando el film lateral, fijándolo con cinta adhesiva de PP o PVC de unos 50mm de anchura.

STP SILENT UNDERLAY è una schiuma di poliolefina incapsulata, specificatamente progettata e prodotta per essere utilizzata come isolante acustico per pavimenti in legno e laminato.

#### COLLOCAZIONE:

Per la posa, è richiesto un suolo stabile, senza dislivelli e completamente secco (<=2...3 m-% secondo il metodo CM). Se la superficie da rivestire presenta dislivelli superiori ai 2 mm/m deve essere livellata.

Nel caso in cui il pavimento preesistente sia formato da moquette, linoleum, parquet o qualsiasi altro materiale organico, è necessario rimuoverlo.

Togliere qualsiasi elemento estraneo al suolo e stendere man mano il rotolo per l'isolamento acustico, lasciando a vista il lato marcato.

Durante l'operazione di stesura, evitare la formazione di pieghe e unir tra loro i lembi sovrappoendo la pellicola laterale fissandola con nastro adesivo in PP o PVC da 50 mm di larghezza.

STP 静音地垫是为木地板和强化地板专门开发和设计的声学底层的闭孔聚烯烃泡沫。

#### 装置:

为了安装层，地板必须稳定，无水差异，完全干燥（根据CM法，<= 2 ... 3 M-%）。如果不平坦度超过2mm / m，则必须先对地板进行调平。如果地板上装地毯，油毡，木地板或其他任何有机材料，则必须在开始安装前将其取下。从地板上取下任何物体，并开始拉伸隔离层，因为我们安装镶木地板，打印面朝上。拉伸层，使其不起皱，并通过胶片与合适的约束连接在一起。50毫米宽的PP或PVC粘合胶带。

**AIDICO**  
INSTITUTO TECNOLÓGICO  
DE LA CONSTRUCCIÓN

**CTE**  
CODIGO TÉCNICO  
DE LA EDIFICACIÓN



**Intertek**

# EUROPOSA

**EUROBI 2C<sup>+</sup>**  
EPOXY-POLYURETHANE BI-COMPONENT ADHESIVE



Bicomponent epoxy-polyurethane adhesive completely odorless water-free and solvent-free, suitable for laying traditional or prefinished wooden floors on any kind of surfaces, also pre-existent and nonabsorbent ones (ceramic, marble, etc.). Eurobi 2C+ Solvent Free guarantees high elasticity and a long time of use. Suitable on underfloor heating systems. The absence of solvents and the very low concentration of other substances volatile organic ensures greater safety for the user and compliance with environmental quality.

Adhesivo bicomponente de epoxi-poliuretano completamente inodoro, sin agua ni solventes, indicado para instalar pavimentos de madera tradicional o preacabada sobre cualquier tipo de superficie, incluyendo pavimentos preexistentes no absorbentes (cerámica, mármol, etc.). Eurobi 2C+ libre de solventes, garantiza una alta capacidad de manipulación, elasticidad y durabilidad. Indicado para suelo radiante. La ausencia de solventes y la muy baja concentración de otras sustancias orgánicas volátiles garantizan una mayor seguridad para el usuario y el respeto a la calidad ambiental.

Adesivo bicomponente epossipoliuretano completamente inodore esente da acqua e solventi, idoneo per la posa di pavimenti in legno tradizionali o prefiniti su qualsiasi tipo di supporto, anche preesistente ed inassorbente (ceramica, marmo, ecc.). Eurobi 2C+ Solvent Free garantisce elevata lavorabilità, elasticità e lunga durata. Idoneo su impianti di riscaldamento a pavimento. L'assenza di solventi e la bassissima concentrazione di altre sostanze organiche volatili garantisce maggiore sicurezza per l'utilizzatore e rispetto della qualità ambientale.

双组分环氧聚氨酯粘合剂完全无味、无水和无溶剂，适用于在任何类型的表面上铺设传统或预制木地板，也适用于预先存在的和非吸水的（陶瓷、大理石等）。Eurobi 2C+无溶剂保证了高可操作性、弹性和长时间使用。适用于地暖系统。缺乏溶剂和其他挥发性有机物质的浓度非常低，确保了用户的更大安全性和对环境质量的合规性。

**EUROMONO<sup>+</sup>**  
SILANE-MODIFIED MONO-COMPONENT ADHESIVE



Mono-component adhesive based on silane polymers for elastic bonding of wooden floors. It is water and solvent free, it does not contain epoxy resins nor isocyanate. It is suitable for engineered wood floorings of any species and dimensions. It is also suitable for solid wood up to 140 mm width on any type of absorbent and non absorbent sub-floors. Thanks to its elasticity, it is particularly recommended on under-floor heating and cooling systems; it does not swell and has got goodsound proofing properties. Easy to use, high yield, no waste, easy to clean from hands and prefinished parquet, Euromono+ has no symbol of risk and a very low VOC content.

Adhesivo monocomponente basado en polímeros de silano para la unión elástica de pavimentos de madera. No contiene agua ni solventes, ni tampoco resinas epoxi ni isocianato. Indicado para pavimentos de madera mecanizada de cualquier tipo y tamaño. También está indicado para madera maciza de hasta 140 mm de ancho sobre cualquier tipo de subsuelo, absorbente y no absorbente. Gracias a su elasticidad, se recomienda particularmente en los sistemas de climatización por suelo radiante/refrescante; no se hincha y tiene propiedades insonorizantes. Fácil de usar, de un alto rendimiento, sin desperdicio. Es fácil de limpiar de las manos y del parquet preacabado, Euromono+ no simboliza ningún riesgo y tiene un contenido de VOC muy bajo.

Adesivo monocomponente a base di polimeri silanici per l'incollaggio elastico di pavimenti in legno. È esente da acqua e solventi, non contiene resine epossidiche né isocianati. È adatto per pavimentazioni in legno composito di qualsiasi specie e dimensione. È adatto anche per legno massiccio fino a 140 mm di larghezza su qualsiasi tipo di sottofondo assorbente e non assorbente. Grazie alla sua elasticità è particolarmente indicato su impianti di riscaldamento e raffrescamento a pavimento; non rigonfia ed ha buone proprietà fonoassorbenti. Facile da usare, ad alta resa, senza sprechi, facile da pulire dalle mani e dal parquet prefinito, Euromono+ non presenta alcun simbolo di rischio e un bassissimo contenuto di COV.

基于硅烷聚合物的单组份粘合剂，用于木地板的弹性粘合。它不含水和溶剂，不含环氧树脂和异氰酸酯。它适用于任何种类和尺寸的工程木地板。它也适用于任何类型的吸水性和非吸水性子地板上宽度高达140毫米的实木。由于其弹性，它特别推荐用于地暖和冷却系统；它不会膨胀，并具有良好的隔音性能。易于使用，产量高，无浪费，易于用手和预成品镶木地板清洁，Euromono+没有风险的象征，挥发性有机化合物含量非常低。

<b>EUROBI 2C<sup>+</sup> Chemical-Physical characteristics (20°C - 60% R.H.)</b>			
<b>Component A appearance</b>	Thick paste	Specific gravity of mix (UNI EN 542)	1,699 g/cm <sup>3</sup>
<b>Component B appearance</b>	Liquid paste	Concentration of solvents	Zero VOC
<b>Mixture viscosity (Brookfield rev.nr.7 50 rpm)</b>	49000 mPa		
Mixing ratios and Times (20°C - 60% R.H.)			
<b>Mixing ratio A + B</b>	99 + 11 in weight	Set to traffic	24 h
<b>Pot life</b>	90 min	Polishing	2 - 3 days
<b>Adjustment time</b>	8 - 10 h	Possible dilution	Max 100 ml P.E.P. promoter
Technical characteristics (20°C - 60% R.H.)			
<b>Consumption (10 mm notched trowel)</b>	1000 - 1500 gr/m <sup>2</sup>	Application temp.	> 10°C < 35°C
<b>Shear strenght (Rif. EN 14293)</b>	> 3,5 N/mm <sup>2</sup>		
ADHESIVE COMPLIANT UNI EN 14293			
Storage & Labeling			
<b>Storage in original packaging sealed at T&gt; 10 ° C</b>	12 months	Symbols of danger	Comp. A: Xi Comp. B: Xi
<b>Packaging</b>	Buckets 9,9 Kg + 1,1 Kg		



<b>EUROMONO<sup>+</sup> Physical characteristics (20°C - 60% R.H.)</b>			
<b>Aspect</b>	Thixotropic paste	Viscosity (Brookfield spindle 7 - 50 rpm)	35000 mPa.s
<b>Density</b>	1,7 g/cm <sup>3</sup>		
Times (20°C - 60% R.H.)			
<b>Opening time</b>	40 - 60 min	Light traffic	6 - 10 hours
<b>Hardening time</b>	8 - 10 h	SandingW	2 - 3 days
Technical characteristics (20°C - 60% R.H.)			
<b>Yield (spatula 8 mm)</b>	700 - 1200 gr/m <sup>2</sup>	Water resistance	excellent
<b>Shear strenght (UNI EN 14293)</b>	1,2 N/mm <sup>2</sup>	Shear elongation factor (UNI EN 14293)	> 2
<b>Chemical resistance</b>	excellent	Application temperature	> + 10°C
Storage & Labeling			
<b>Shelf-life in original unopened packaging at ambient temperature in a fresh and dry space</b>	12 months	Symbols of risk	None
<b>Packaging</b>	Bucket of 15 Kg		



# INSTALLATION PROCEDURE

PROCEDIMIENTO DE INSTALACION / PROCEDURE D'INSTALLAZIONE / 安装程序

**LOCKSTP**<sup>®</sup>  
EXCELLENT GLUELESS SYSTEM

Patent-protected  
worldwide

## SUBFLOOR CONDITION:

- All subfloors must be dry and free from dirt and contamination.
- The subfloor must be leveled to no more than a 3 mm gap showing under a 3 meter straight edge.
- When measured with a hygrometer, it is reasonable to recommend that the concrete be considered dry when the relative humidity is 40-60% (maximum limit of 2% CM for concrete soil, 0.5% CM for anhydrite subfloor). Risks of infiltration should be carefully avoided.

## TYPES OF SUBFLOOR:

- Concrete: Measure the humidity conditions of the floor. If they prove to be damp, a membrane must be installed prior to fitting any LockSTP product (maximum limit of 2% CM for concrete soil, 0.5% CM for anhydrite subfloor). In addition, the surface of the concrete should be left slightly rough to ensure an adequate adherence for the adhesive to stick. Risks of infiltration should be carefully avoided.

- Wooden floorboards: Must be sturdy, free from decomposition, level and no cracking noises upon pressure.

There should be adequate ventilation under the floorboards.

- Chipboard: The surface must be flat, smooth and of a moisture resistant flooring grade.

## INSTALLATION OVER UNDERFLOOR HEATING:

- LockSTP products can be installed over underfloor central heating provided that the floor surface temperature does not exceed 27°C and the subfloor must be dry.

We recommend installing a membrane 4mm + over heated floor system prior to wood floor installation.

- If this is a new underfloor heating system, it must have been commissioned and running for 4 weeks and then switched off 48 hours. Prior to installing, it is compulsory to measure the relative humidity, as it must be 40-60% (should not exceed the maximum limit of 1.7% CM). Please follow heating floor system guidelines in correspondence with STP.

- 48 hours after installation, the heating floor thermostat must be turned on and gradually brought up to normal working temperature over 10 days. An alternative dry source of heat must be provided whilst installation is in progress to ensure a constant room temperature of 20-21°C.

## INSTALLATION OVER EXISTING HARD FLOOR COVERINGS:

- LockSTP products can be laid over existing hard floorcoverings such as ceramic tiles, marble etc. The existing floorcovering must be firmly secured to the subfloor and be clean and free of any residue or dirt. If necessary, the surface should be "roughened" to create suitable adherence conditions. (Any hard floorcoverings laid directly to earth such as quarry tiles or concrete must incorporate a damp proof membrane).

## SET UP CONDITIONS PRIOR TO INSTALLATION:

- Wood packages should be on site 1 week prior to installation.
- All trades (carpentry, masonry, plumbing and electrical) should be free of area to commence work.
- Windows and exterior doors should be installed.
- Drywall and painting finished, except for the last coat of paint. Walls and ceiling can be wallpapered and/or it can be applied the last coat of paint after installing the flooring, but the flooring must be previously well covered and protected.
- Temperature and humidity content should be as follows; Temperature of 19°C to 20°C with humidity ranging between 40 to 60%.

## INSTALLER AND OWNER'S RESPONSIBILITY:

Prior to laying the floor, the installer and the owner must make sure that the installation site and subfloor comply with the conditions specified in this document. The installer and the buyer have the responsibility to inspect the wood boards prior to their installation. STP products meet stringent quality standards and comply with the standards in force in the wood flooring industry. These allow a rate of imperfection not exceeding 10% of the quantity of the purchased boards. This rate includes both the natural imperfections of the wood as well as defects in manufacturing and selection of the grade. If the installer doubts the grade selection, the manufacturing or finishing quality, and it cannot place the board in a less conspicuous place, or eliminate imperfection, he/she should not install it. Once the board is installed, it shall be considered as having been accepted by the installer and the owner.

According to the site and the type of installation, the order for the STP products should provide for between 7-15% additional recovery (depending on the format) to compensate for the loss caused by the cuts. STP will only replace products with a defect rate exceeding the acceptable 10% (excluding the 7-15% cutting loss). STP cannot be held liable for improper installation of its products or poor judgment by the installer. STP assumes no labor or installation charges.

## RECOMMENDATIONS FOR LAYING THE FLOORS:

- Open several cartons at a time to mix the boards in such a way that the board characteristics are well distributed across the floor.
- During installation, place tools and hammer on a protected surface.
- Before starting installation, cut the bottom of the moldings around the doors to insert the boards.
- Plan your project by making a sketch of the installation.

- Determine the starting point of the installation.

## FLOATING INSTALLATION WITH LOCKSTP SYSTEM

A floating installation is one in which the pavement is installed without a fixed connection with the subfloor, ie only one piece is attached to the other. The floor can move freely on the ground. The installation of a floor of STP can be performed with ease and security of union between parts thanks to the LockSTP system. The union of the pieces is ensured by two systems, an alternating tongues and grooves system in a modular size of 290 mm dovetailed to the contour perimeter of the pieces to ensure a perfect flush of the joints, and by lower grooves through which precise interlocking rings slip to bind the pieces together.

- After satisfying the general requirements for the installation of a LockSTP floor proceed as follows: wide the insulation blanket (STP Underlay) suitable for every type of installation ensuring that the plastic face remains upwards, avoiding the formation of creases and attaching without overlaps with adhesive strips.
- Continue the placement according to the format and pattern selected (please see its corresponding mounting scheme in the section for that purpose).
- It is necessary to keep expansion joints separated from the fixed elements such as walls, columns and pipes, of about 12 mm. If the surface to be installed is a big one (about 10m long and 8m wide), STP recommends the use of board dilatation, mainly in planks.
- Warning: Cut tongues corresponding to the sides of the pieces which must remain separated from fixed element, not to subtract space to the expansion. Do not cut them when the union is made with our board dilatation.

- Install the skirting using polyurethane silicone for a better finish, join the skirting pieces on 45° and join together with white glue.

- Finally wipe the floor with a vacuum cleaner, mop or broom and end with a damp cloth and a cleaner for wood.

## GLUED DOWN INSTALLATION WITH T&G PLANKS

**Note; Woodpeak products must be installed compulsorily with bi-component adhesive since it is faster to dry and stronger than mono-component.**

## BOARD INSTALLATION:

- Using chalk line, draw a line parallel to the starting wall at a distance of 13mm (0.51") more than the width of the boards (e.g.: 158mm (6.22") for 145mm (5.71") boards, 208mm (8.19") for 195mm (7.68") boards). The space between the wall and the starting point is the last section of floor that will be installed.

- Nail the furring guides inside the work area along the line. The latter will serve as point of support points for installation of the first boards.

- In advance, spread out 4 to 5 rows of assorted boards according to joints and colors.

- From the starting point outward, apply the adhesive with the trowel at 45°.

- Install the first board along the starting line so that the tongue is facing you and the groove faces the starting wall. Always keep 19mm (0.75") expansion gap at the end of rows.

- Proceed in small sections so that the adhesive does not dry before the boards are installed.

- Install the other boards in the row progressing from left to right.
- The last row board will have to be cut. The scrap part may be used to start the next row.

- For the next rows, insert the tongue into the groove and lower the boards into the adjacent board and avoid touching the adhesive. A hammer block may be required to enter the tongue into the groove.

- Apply adhesive tape, suitable for wooden floors, onto each 5 or 6 rows to ensure that boards remain securely in place.

- **Attention; in wide/long plank installation, tape must be added on the length and ends of each plank. Brace the perimeters and use fastening straps and weights until glue has cured.**

- Use a 45.4 to 68 kg (100 to 150 lb.) roller to apply pressure on the fitted sections while the adhesive is still active (about 45 to 60 min.). Repeat these steps for the entire floor.

- For best results, stagger the end-joints 145mm to 290mm (5.71" to 11.42") from the previous row and alternate the length of the boards.

- Once the surface is completely covered, remove the straight edge and place the boards within the 158mm (6.22") space left free at the start of the installation.

Important: During installation, immediately wipe off any adhesive from the surface of the flooring.

## PROTECTING YOUR FLOORS UPON COMPLETION:

- IT'S VERY IMPORTANT TO MAINTAIN THE FLOORS COVERED WITH A NON ABRASIVE MATERIAL TO PROTECT THEM FROM OTHERS TRADES. Do NOT place heavy objects as it may damage floors due to pressure points. Do NOT use any adhesive or tape directly onto floor surface as this may cause damages. Temperature and humidity content should remain and be as follows; Temperature of 19°C to 20°C with humidity ranging between 40 to 60%.

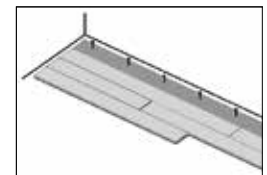
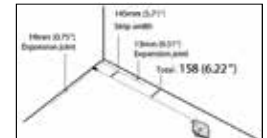

Please protect your installed floor until all trades on site have been finished to avoid damages, especially on Hand-scraped, Hammered and Cross-cut finishes because the dirt may remain on the grain and will then be very difficult to remove.

#### ESTADO DEL SUBSUELO:

- Todos los subsuelos deben estar secos y libres de polvo y suciedad.
- El subsuelo debe tener un desnivel máximo de 3 mm por cada tramo de 3 metros.
- Cuando se mide con un higrómetro, se puede considerar que el cemento está seco, cuando su humedad relativa es del 40-60% (límite máximo del 2% CM para suelo de hormigón, 0,5% CM para subsuelo anhidrita). Se recomienda evitar los riesgos de infiltración de humedad.

#### TIPOS DE SUBSUELO:

- Hormigón: Medir las condiciones de humedad del suelo. Si resulta estar húmedo, se debe instalar una membrana de material hidrófugo antes de instalar cualquier producto LockSTP. Además, la superficie de la base debe quedar ligeramente rugosa para asegurar una adecuada adherencia de la cola.

Se deben evitar cuidadosamente los riesgos de infiltración.

- Suelos de madera: deben ser firmes, libres de suciedad, estar nivelados y no moverse, o sea sin crujidos (como mínimo deben estar clavados al suelo y formar una superficie plana para poder instalar el suelo STP).

Debe haber una adecuada ventilación bajo las tablas del suelo.

- Aglomerado: La superficie de aglomerado debe ser plana, lisa y resistente a la humedad.

#### INSTALACIÓN SOBRE SUELO RADIANTE:

- Los productos LockSTP se pueden instalar sobre calefacción central por suelo radiante siempre que la temperatura superficial del suelo no supere los 27°C y el subsuelo esté seco.

Recomendamos instalar una membrana de 4 mm sobre el sistema de suelo radiante antes de la instalación de madera.

- Si se trata de un sistema de calefacción por suelo radiante nuevo, éste deberá haber estado puesto en funcionamiento y funcionando durante 4 semanas y luego apagado durante un período de 48 horas. Antes de la instalación, es necesario medir la humedad relativa, ya que debe ser de 40-60% (no debe exceder el límite máximo de 1.7 % CM). Siga las pautas del sistema de calefacción radiante de acuerdo con STP.

- 48 horas después de la instalación, se debe encender la calefacción y hacerla llegar gradualmente a su temperatura habitual de funcionamiento durante unos 10 días. Mientras se está efectuando la instalación, se debe proporcionar una fuente alternativa de calor seco para garantizar una temperatura ambiente constante de 20-21°C.

#### INSTALACIÓN SOBRE PAVIMENTOS EXISTENTES:

- Los productos LockSTP se pueden colocar sobre pavimentos compactos existentes como cerámica, mármol, etc, siempre que el pavimento existente esté firmemente anclado al suelo base y que la superficie del pavimento esté limpia, es decir, que se haya eliminado cualquier resto de suciedad de la superficie. Si es necesario, la superficie debe ser "rugosa" para crear las condiciones óptimas de adherencia. (Para cualquier tipo de pavimento compacto, colocado directamente a tierra, tales como baldosas de piedra natural, se debe aplicar una membrana de material hidrófugo).

#### CONDICIONES DE CONFIGURACIÓN PREVIAS A LA INSTALACIÓN:

- Los paquetes de pavimento de madera deben estar en el sitio 1 semana antes de la instalación.
- La obra debe estar libre de otros oficiales. Todos los trabajos de carpintería, albañilería, fontanería y electricidad deben haber terminado antes de comenzar a trabajar.
- Se deben haber instalado todas las puertas y ventanas exteriores.
- Las paredes y techos deben haber sido pintados y haberse secado, a falta de la última mano de pintura. Se puede empapelar paredes y techos, y/o aplicar la última mano de pintura después de la instalación del pavimento, pero el suelo deberá estar bien cubierto y protegido.
- El contenido de temperatura y humedad debe ser el siguiente; Temperatura de 19°C a 20°C con humedad atmosférica que oscila entre el 40 y el 60%.

#### RESPONSABILIDAD DEL INSTALADOR Y DEL PROPIETARIO:

Antes de colocar el pavimento, el instalador y el propietario deben asegurarse de que el lugar de instalación y el subsuelo cumplan con las condiciones especificadas en este documento. El instalador y el comprador tienen la responsabilidad de inspeccionar los tableros de madera antes de su instalación. Los productos STP cumplen con estrictos estándares de calidad y cumplen con las normas vigentes en la industria de los pisos de madera. Estos permiten un índice de imperfección que no supera el 10% de la cantidad de tableros adquiridos. Este margen incluye tanto las imperfecciones naturales de la madera como los defectos de fabricación y selección de la calidad. Si el instalador duda de la selección del grado, la calidad de fabricación o acabado y no puede colocar el tablero en un lugar menos visible, o eliminar las imperfecciones, no deberá instalarlo. Una vez instalada la pieza se considerará aceptada por el instalador y el propietario. Según el lugar y el tipo de instalación, el pedido de productos STP debería prever entre un 7 y un 15% de recuperación adicional (según el formato) para compensar la pérdida provocada por los cortes. STP solo reemplazará productos con una tasa de defectos que exceda el 10% aceptable (excluyendo la pérdida de corte del 7-15%). STP no se hace responsable de la instalación incorrecta de sus productos o del mal criterio del instalador. STP no asume cargos de mano de obra ni de instalación.

#### RECOMENDACIONES PARA LA COLOCACIÓN DEL PAVIMENTO:

- Abrir varias cajas a la vez para mezclar las piezas de tal manera que las características del producto escogido queden bien distribuidas por todo el piso.
- Durante la instalación, se deben colocar las herramientas y martillo en una superficie protegida.
- Antes de comenzar la instalación, es necesario cortar la parte inferior de las molduras alrededor de las puertas para insertar las piezas de suelo.
- Es conveniente planificar el proyecto realizando un boceto de la instalación.
- Determinar el punto de partida de la instalación.

#### INSTALACIÓN FLOTANTE CON SISTEMA LOCKSTP

Una instalación flotante es aquella en la que el pavimento se instala sin unión fija con el subsuelo, es decir, únicamente se une una pieza con otra. El suelo puede moverse libremente sobre el subsuelo. La instalación de un suelo STP puede llevarse a cabo con facilidad y con la seguridad de unión entre piezas gracias al sistema LockSTP. La unión de las piezas queda asegurada mediante dos sistemas, un sistema de machihembrado alterno y autocentrante de tamaño modular de 290 mm mecanizado en el contorno perimetral de las piezas que garantiza un enrasado de juntas perfecto, y mediante unos surcos inferiores por los que se deslizan unos precisos anillos de enclavamiento que unen las piezas entre sí.

- Una vez cumplidos los requisitos generales para la instalación de un suelo LockSTP, proceda de la siguiente manera: extienda la manta aislante (STP Underlay) adecuada para cada tipo de instalación, asegurándose de que la cara plástica quede hacia arriba, evitando la formación de pliegues y uniéndola sin solapes con tiras adhesivas.

- Continúe la colocación según el formato y patrón seleccionado (véase su correspondiente esquema de montaje en el apartado destinado a tal efecto).

- Es necesario mantener juntas de dilatación respecto a los elementos fijos como paredes, columnas y tuberías, de unos 12 mm. Si la superficie a instalar es grande (de unos 10m de largo y 8m de ancho), STP recomienda el uso de juntas de dilatación, principalmente en listones.

- Atención: Corte los machos perimetrales correspondientes a los lados de las piezas que guarden junta de separación a elementos fijo, para no restar espacio de dilatación. No cortar cuando se ensamblen a nuestra junta de dilatación.

- Instale el rodapié utilizando silicona de poliuretano para un mejor acabado, una las piezas de rodapié a inglete a 45° y fíjelas entre sí con cola blanca.

- Finalmente limpie el suelo con aspiradora, mopa o escoba y remate con un paño húmedo y un limpiador para madera.

#### INSTALACIÓN ENCOLADA CON SISTEMA T&G

**Nota; Los productos Woodpeak deben instalarse obligatoriamente con adhesivo bicomponente ya que es de secado más rápido y más resistente que el monocomponente.**

#### INSTALACIÓN DE LISTONES:

- Usando hilo de tiza, dibuje una línea paralela a la pared inicial a una distancia de 13 mm (0,51") más que el ancho de las tablas (por ejemplo: 158 mm (6,22") para piezas de 145 mm (5,71"), 208 mm (8,19") para piezas de 195 mm (7,68")). El espacio entre la pared y el punto de partida es la última porción de suelo que se instalará.

- Clave las guías de enrasar dentro del área de trabajo a lo largo de la línea. Estas últimas servirán como punto de apoyo para la instalación de las primeras tablas.

- Distribuya previamente de 4 a 5 filas de piezas surtidas según malla y color.

- Desde el punto inicial hacia afuera aplicar el adhesivo con la espátula correspondiente a 45°.

- Instale la primera pieza a lo largo de la línea de inicio de modo que el macho mire hacia usted y la hembra mire hacia la pared de inicio. Mantenga siempre un espacio de dilatación de 19 mm (0,75") al final de las filas.

- Proceder en pequeños tramos para que el adhesivo no se seque antes de instalar las piezas.

- Instale las otras piezas en la fila avanzando de izquierda a derecha.
- Será necesario cortar la pieza de la última fila. La parte sobrante se puede utilizar para comenzar la siguiente fila.

- Para las siguientes filas, inserte el macho en la hembra y baje la pieza hacia la pieza adyacente, evitando tocar el adhesivo. Es posible que se requiera un martillo de goma para introducir el macho en la hembra.

- Aplique cinta adhesiva, adecuada para suelos de madera, en cada 5 o 6 filas para garantizar que las piezas permanezcan fijas en su lugar.

- **Atención; en la instalación de listones anchos/largos, se debe agregar cinta adhesiva a lo largo y en los extremos de cada pieza. Apoye los perímetros y use correas de sujeción y peso hasta que el pegamento se haya secado.**

- Utilice un rodillo de 45,4 a 68 kg (100 a 150 lb) para aplicar presión sobre las secciones instaladas

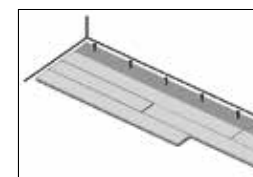
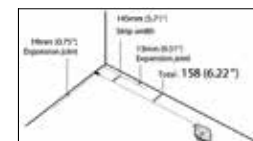

mientras el adhesivo aún está activo (aproximadamente 45 a 60 minutos). Repita estos pasos para todo el piso.

- Para obtener mejores resultados, escalone las juntas de los extremos de 145 mm a 290 mm (5,71" a 11,42") de la fila anterior y alterne la longitud de las tablas.
- Una vez que la superficie esté completamente cubierta, retire la regla y coloque las piezas dentro del espacio de 158 mm (6,22") que quedó libre al inicio de la instalación.

Importante: Durante la instalación, limpie inmediatamente cualquier adhesivo de la superficie del piso.

#### PROTECCIÓN DEL PAVIMENTO AL TERMINAR:

- ES MUY IMPORTANTE MANTENER LOS PISOS CUBIERTOS CON UN MATERIAL NO ABRASIVO PARA PROTEGERLOS DE OTROS TRABAJOS. NO coloque objetos pesados ya que puede dañar los pisos debido a los puntos de presión. NO utilice ningún adhesivo o cinta adhesiva directamente sobre la superficie del piso, ya que esto puede causar daños. El contenido de temperatura y humedad debe permanecer y ser el siguiente; Temperatura de 19°C a 20°C con humedad atmosférica que oscila entre el 40 y el 60%. Proteja su suelo instalado hasta que se hayan terminado todos los trabajos en la obra para evitar daños, especialmente en acabados Hand-scraped, Hammered y Cross-cut, porque la suciedad puede permanecer en la veta y luego será muy difícil eliminarla.

#### CONDIZIONE DEL SOTTO-PAVIMENTO:

- Tutti i sottopavimenti devono essere asciutti e privi di sporco e contaminanti.
- Il sottopavimento deve essere livellato a non più di 3 mm di spazio visibile sotto un bordo dritto di 3 metri.
- Quando misurato con un igrometro, è ragionevole raccomandare che il calcestruzzo sia considerato asciutto quando l'umidità relativa è del 40-60% (limite massimo 2% CM per terreno in calcestruzzo, 0,5% CM per sottopavimento in anidrite).

I rischi di infiltrazione devono essere attentamente evitati.

#### TIPOLOGIE DI SOTTO-PAVIMENTO:

- Calcestruzzo: misurare le condizioni di umidità del pavimento. Se risultano umidi, è necessario installare una membrana prima di installare qualsiasi prodotto LockSTP (limite massimo di 2% CM per terreno in cemento, 0,5% CM per sottopavimento in anidrite). Inoltre la superficie del calcestruzzo dovrà essere lasciata leggermente ruvida per garantire un'adeguata aderenza all'adesione dell'adesivo. I rischi di infiltrazione devono essere attentamente evitati.
- Assi del pavimento in legno: devono essere robuste, esenti da decomposizione, livellate e senza rumori di scricchiolio alla pressione.

Dovrebbe esserci un'adeguata ventilazione sotto le assi del pavimento.

- Truciolato: la superficie deve essere piana, liscia e resistente all'umidità.

#### INSTALLAZIONE SU RISCALDAMENTO A PAVIMENTO:

- I prodotti LockSTP possono essere installati su riscaldamento centralizzato a pavimento a condizione che la temperatura della superficie del pavimento non superi i 27°C e il sottopavimento deve essere asciutto. Si consiglia di installare una membrana di 4 mm+ sul sistema a pavimento riscaldato prima dell'installazione del pavimento in legno.
- Se si tratta di un nuovo sistema di riscaldamento a pavimento, deve essere stato messo in funzione e in funzione per 4 settimane e poi spento per 48 ore. Prima dell'installazione è obbligatorio misurare l'umidità relativa, che deve essere pari al 40-60% (non deve superare il limite massimo di 1,7% CM). Si prega di seguire le linee guida del sistema di riscaldamento a pavimento in conformità con STP.
- Dopo 48 ore dall'installazione, il termostato del riscaldamento a pavimento deve essere acceso e portato gradualmente alla temperatura di esercizio normale nell'arco di 10 giorni. Durante l'installazione è necessario fornire una fonte alternativa di calore secco per garantire una temperatura ambiente costante di 20-21°C.

#### POSA SU PAVIMENTAZIONI DURE ESISTENTI:

- I prodotti LockSTP possono essere posati su rivestimenti duri esistenti come piastrelle in ceramica, marmo, ecc. Il rivestimento esistente deve essere fissato saldamente al sottopavimento ed essere pulito e privo di residui o sporco. Se necessario la superficie dovrà essere "irruvidita" per creare idonee condizioni di aderenza. (Qualsiasi pavimentazione dura posata direttamente su terra, come piastrelle di cava o cemento, deve incorporare una membrana anti-umidità).

#### CONDIZIONI DI IMPOSTAZIONE PRIMA DELL'INSTALLAZIONE:

- I pacchetti di legno dovrebbero essere sul posto 1 settimana prima dell'installazione.
- Tutte le attività ( falegnameria, muratura, idraulica ed elettricità) devono essere libere da un'area per iniziare i lavori.
- Dovrebbero essere installate finestre e porte esterne.
- Cartongesso e tinteggiatura finiti, ad eccezione dell'ultima mano di vernice. Pareti e soffitto possono essere tappezzati e/o può essere applicata l'ultima mano di vernice dopo la posa del pavimento, ma il pavimento deve essere preventivamente ben coperto e protetto.
- Il contenuto di temperatura e umidità dovrebbe essere il seguente; Temperatura da 19°C a 20°C con umidità compresa tra il 40 e il 60%.

#### RESPONSABILITÀ DELL'INSTALLATORE E DEL PROPRIETARIO:

Prima della posa del pavimento, l'installatore e il proprietario devono assicurarsi che il luogo di installazione e il sottopavimento rispettino le condizioni specificate nel presente documento. L'installatore e l'acquirente hanno la responsabilità di ispezionare le tavole di legno prima della loro installazione. I prodotti STP soddisfano severi standard qualitativi e sono conformi alle normative vigenti nel settore dei pavimenti in legno. Questi consentono un tasso di imperfezione non superiore al 10% della quantità delle tavole acquistate. Questa tariffa comprende sia le imperfezioni naturali del legno che i difetti di fabbricazione e di selezione della qualità. Se l'installatore dubita della scelta del grado, della qualità di fabbricazione o di finitura e non può posizionare il pannello in un punto meno visibile o eliminare le imperfezioni, non dovrebbe installarlo. Una volta installata la scheda, questa sarà considerata accettata dall'installatore e dal proprietario. A seconda del sito e del tipo di installazione, l'ordine dei prodotti STP dovrebbe prevedere un recupero aggiuntivo dal 7 al 15% (a seconda del formato) per compensare la perdita causata dai tagli. STP sostituirà solo i prodotti con un tasso di difetto superiore al 10% accettabile (esclusa la perdita di taglio del 7-15%). STP non può essere ritenuta responsabile per un'installazione non corretta dei suoi prodotti o per scarsa capacità di giudizio da parte dell'installatore. STP non si assume alcun costo di manodopera o installazione.

#### CONSIGLI PER LA POSA DEI PAVIMENTI:

- Aprire più cartoni alla volta per mescolare le tavole in modo tale che le caratteristiche delle tavole siano ben distribuite sul pavimento.
- Durante l'installazione, posizionare gli attrezzi e il martello su una superficie protetta.
- Prima di iniziare l'installazione, tagliare il fondo delle modanature attorno alle porte per inserire le tavole.
- Pianifica il tuo progetto realizzando uno schizzo dell'installazione.
- Determinare il punto di partenza dell'installazione.

#### INSTALLAZIONE FLOTTANTE CON SISTEMA LOCKSTP

Una posa flottante è quella in cui la pavimentazione viene installata senza un collegamento fisso con il sottopavimento, cioè solo un pezzo è attaccato all'altro. Il pavimento può muoversi liberamente sul terreno. L'installazione di un pavimento in STP può essere eseguita con facilità e sicurezza di unione tra le parti grazie al sistema LockSTP. L'unione dei pezzi è assicurata da due sistemi, un sistema di linguette e scanalature alternate di dimensione modulare di 290 mm incastrate al contorno perimetrale dei pezzi per garantire un perfetto complanare delle giunzioni, e da scanalature inferiori attraverso le quali precisi anelli ad incastro scivolare per unire i pezzi insieme.

- Dopo aver soddisfatto i requisiti generali per la posa di un pavimento LockSTP procedere come segue: allargare il materassino isolante (STP Underlay) adatto ad ogni tipo di posa assicurandosi che la faccia plastica rimanga verso l'alto, evitando la formazione di pieghe e fissando senza sormonti con adesivo strisce.
- Continuare il posizionamento in base al formato e al modello selezionati (vedere lo schema di montaggio corrispondente nella sezione a tale scopo).
- È necessario mantenere separati i giunti di dilatazione dagli elementi fissi quali pareti, colonne e tubazioni, di circa 12 mm. Se la superficie da installare è di grandi dimensioni (circa 10 m di lunghezza e 8 m di larghezza), STP consiglia l'utilizzo della dilatazione delle tavole, prevalentemente in listoni.
- Attenzione: Tagliare le alette in corrispondenza dei lati dei pezzi che devono rimanere separati dall'elemento fisso, per non sottrarre spazio alla dilatazione. Non tagliarli quando si effettua l'unione con la nostra dilatazione della tavola.

- Installare il battiscopa utilizzando silicone poliuretano per una migliore finitura, unire i pezzi del battiscopa a 45° e unirli con colla bianca.
- Passare infine il pavimento con aspirapolvere, mop o scopa e terminare con un panno umido e un detergente per legno.

#### POSA INCOLLATA CON DOGHE T&G

**Nota; I prodotti Woodpeak devono essere installati obbligatoriamente con adesivo bicomponente poiché è più veloce ad asciugarsi e più resistente del monocomponente.**

#### INSTALLAZIONE SCHEDA:

- Usando il gesso, tracciare una linea parallela al muro di partenza ad una distanza di 13 mm (0,51") maggiore della larghezza delle tavole (es.: 158 mm (6,22") per tavole da 145 mm (5,71"), 208 mm (8,19") ) per schede da 195 mm (7,68"). Lo spazio tra il muro e il punto di partenza è l'ultima sezione di pavimento che verrà installata.

- Inchiodare le guide furring all'interno dell'area di lavoro lungo la linea. Quest'ultimo servirà come punto di appoggio per l'installazione delle prime tavole.
- Disporre preventivamente da 4 a 5 file di tavole assortite per giunture e colori.
- Dal punto di partenza verso l'esterno, applicare l'adesivo con la spatola a 45°.
- Installa la prima tavola lungo la linea di partenza in modo che la

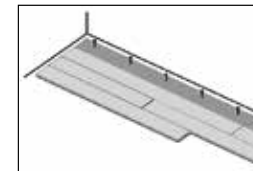
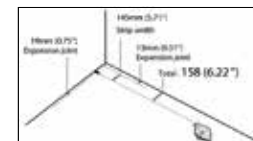

linguetta sia rivolta verso di te e la scanalatura sia rivolta verso la parete di partenza. Mantenere sempre uno spazio di dilatazione di 19 mm (0,75") alla fine delle file.

- Procedere per piccoli tratti in modo che l'adesivo non si asciughi prima della posa delle lastre.
  - Installare le altre tavole nella fila procedendo da sinistra a destra.
  - L'ultima fila di assi dovrà essere tagliata. La parte di scarto può essere utilizzata per iniziare la riga successiva.
  - Per le file successive, inserire la linguetta nella scanalatura e abbassare le tavole nella tavola adiacente evitando di toccare l'adesivo. Potrebbe essere necessario un blocco del martello per inserire la linguetta nella scanalatura.
  - Applicare nastro adesivo, adatto per pavimenti in legno, su ogni 5 o 6 file per garantire che i pannelli rimangano saldamente in posizione.
  - Attenzione; nell'installazione di doghe larghe/lunghe, è necessario aggiungere del nastro sulla lunghezza e sulle estremità di ciascuna doga. Sostenere i perimetri e utilizzare cinghie e pesi di fissaggio finché la colla non si è indurita.
  - Utilizzare un rullo da 45,4 a 68 kg (da 100 a 150 lb.) per applicare pressione sulle sezioni montate mentre l'adesivo è ancora attivo (da circa 45 a 60 minuti). Ripetere questi passaggi per l'intero piano.
  - Per ottenere i migliori risultati, sfalsare le giunture terminali da 145 mm a 290 mm (da 5,71" a 11,42") rispetto alla fila precedente e alternare la lunghezza delle tavole.
  - Una volta ricoperta completamente la superficie, rimuovere il bordo dritto e posizionare le tavole entro lo spazio di 158 mm (6,22") lasciato libero all'inizio della posa.
- Importante: durante l'installazione, rimuovere immediatamente qualsiasi adesivo dalla superficie del pavimento.

#### PROTEGGI I TUOI PAVIMENTI UNA VOLTA COMPLETATO:

- È MOLTO IMPORTANTE MANTENERE I PAVIMENTI RICOPERTI CON UN MATERIALE NON ABRASIVO PER PROTEGGERLI DA ALTRI LAVORI. NON posizionare oggetti pesanti poiché potrebbero danneggiare i pavimenti a causa dei punti di pressione. NON utilizzare adesivi o nastri direttamente sulla superficie del pavimento poiché ciò potrebbe causare danni. Il contenuto di temperatura e umidità dovrebbe rimanere ed essere il seguente: temperatura da 19°C a 20°C con umidità compresa tra il 40 e il 60%. Si prega di proteggere il pavimento installato fino a quando tutte le lavorazioni in cantiere non saranno state completate per evitare danni, soprattutto su finiture piallate a mano, martellate e tagliate trasversalmente perché lo sporco potrebbe rimanere sulle venature e quindi è molto difficile rimuoverlo.

#### 底層地板狀況:

- 所有底層地板必須乾燥且無污垢和污染。
- 底層地板必須平整至3米直邊下方的間隙不超過3毫米。
- 使用濕度計測量時，建議在相對濕度為40-60%時將混凝土視為乾燥（混凝土土壤的最大限值為2%CM，硬石膏底層地板的最大限值为0.5%CM）。應小心避免滲透風險。

#### 底層地板的類型:

- 混凝土：測量地板的濕度條件。如果證明它們潮濕，則必須在安裝任何 LockSTP 產品之前安裝防水膜（混凝土土壤的最大限制為2%CM，硬石膏底層地板的最大限制為0.5%CM）。此外，混凝土表面應稍微粗糙，以確保粘劑有足夠的附着力。

#### 應小心避免滲透風險。

- 木地板：必須堅固、無分解、平整且受壓時無破裂噪音。

#### 地板下應有足夠的通風。

- 刨花板：表面必須平整、光滑且符合防潮地板等級。

#### 安裝在地暖上:

- LockSTP 產品可以安裝在地板中央供暖系統上，前提是地板表面溫度不超過27° C 並且底層地板必須乾燥。

#### 我們建議在安裝木地板之前安裝4mm + 薄膜+過熱地板系統。

- 如果這是新的地暖系統，則必須已調試並運行4周，然後關閉48小時。安裝前，必須測量相對濕度，必須為40-60%（不得超過最大限值1.7%CM）。請遵循符合STP的地暖系統指南。
- 安裝後48小時後，必須打開地暖溫控器，並在10天內逐漸恢復到正常工作溫度。安裝過程中必須提供替代的干熱源，以確保室溫恒定在20-21° C。

#### 安裝在現有硬地板上:

- LockSTP 產品可以鋪設在現有的硬質地地板覆蓋物上，例如瓷磚、大理石等。現有的地板覆蓋物必須牢固地固定在底層地板上，並且清潔且無任何殘留物或污垢。如有必要，應將表面“粗糙化”以創造合適的粘附條件。（任何直接鋪設在地面上的硬地板覆蓋物，例如采石場瓷磚或混凝土，都必須包含防潮膜）。

#### 安裝前設置條件:

- 木質包裝應在安裝前1周到現場。
- 所有行業（木工、磚石工、管道工和電氣工）都應該有空地來開始工作。
- 應安裝窗戶和外門。
- 干牆和油漆已完成，最後一層油漆除外。牆壁和天花板可以貼壁紙和/或可以在安裝地板後塗上最後一層油漆，但必須事先很好地覆蓋和保護地板。
- 溫度和濕度含量應如下：溫度為19° C至20° C，濕度為40%至60%。

#### 安裝者和所有者的責任:

在鋪設地板之前，安裝人員和業主必須確保安裝地點和底層地板符合本文中規定的條件。安裝者和買方有責任在安裝前檢查木板。STP 產品符合嚴格的质量标准，并符合木地板行业的现行标准。这些允许缺陷率不超过所购板材数量的10%。该比率包括木材的天然缺陷以及制造和等级选择中的缺陷。如果安装者对等级选择、制造或饰面质量有疑问，并且无法将板材放置在不太显眼的地方，或消除缺陷，则不应安装。板材一旦安装完毕，即视为已被安装人员和业主接受。

根据站点和安装类型，STP产品的订单应提供7-15%的额外恢复（取决于格式），以补偿削减造成的损失。STP只会更换缺陷率超过可接受的10%的产品（不包括7-15%的切割损失）。

STP 对其产品安装不当或安装人员判断失误不承担任何责任。STP 不承担人工或安装费用。

#### 鋪設地板的建議:

- 一次打開多個紙箱以混合板材，使板材特性在地板上均勻分布。
- 安裝期間，將工具和錘子放置在受保護的表面上。
- 開始安裝之前，切割門周圍飾條的底部以插入木板。
- 通過繪制安裝草圖來規劃您的項目。
- 確定安裝的起點。

#### 帶 LOCKSTP 系統的浮動安裝

浮動安裝是指路面与底層地板沒有固定連接的安裝方式，即只有一個部件連接到另一個部件上。地板可以在地面上自由移動。借助 LockSTP 系統，STP 地板的安裝可以輕鬆、安全地實現部件之間的結合。部件的結合由兩個系統確保，一個是模塊化尺寸為290毫米的交錯榫舌和凹槽系統，與部件的輪廓周長相結合，

- 以確保接頭完美齊平，另一個是下部凹槽，精確的互鎖環穿過該凹槽 滑動以將碎片粘在一起。
- 滿足 LockSTP 地板安裝的一般要求後，請進行以下操作：加寬適合各種安裝類型的絕緣毯（STP 底層），確保塑料面保持向上，避免形成折痕，並使用粘劑進行無重疊的連接 帶子。
- 根據所選的格式和圖案繼續放置（請參閱相關部分中相應的安裝方案）。
- 伸縮縫應與牆、柱、管道等固定構件保持12mm 左右的距離。如果要安裝的表面較大（長約10m，寬約8m），STP建議採用板式擴孔，主要採用木板。
- 警告：切割與部件側面相對應的舌片，該部件必須與固定元件保持分離，而不是減少擴展空間。當用我們的板擴張進行聯合時，請勿切割它們。

- 使用聚氨酯樹脂安裝踢腳板以獲得更好的表面效果，將踢腳板以45°角連接并用白膠連接在一起。
- 最後用吸塵器、拖把或掃帚擦拭地板，最後用濕布和木材清潔劑擦拭。

#### 使用 T&G 木板膠合安裝

筆記：Woodpeak 產品必須強制使用雙組分粘劑安裝，因為它比單組分粘劑干燥更快且更堅固。

#### 電路板安裝:

- 使用粉筆線，在比板寬度多 13 毫米 (0.51 英寸) 的距離外畫一條平行於起始牆的線 (例如: 145 毫米 (5.71 英寸) 板為 158 毫米 (6.22 英寸), 208 毫米 (8.19 英寸) 板 ) 適用於 195 毫米 (7.68 英寸) 板)。
- 牆壁和起點之間的空間是要安裝的最後一段地板。
- 沿著線將面板導軌釘在工作區域內。後者將作為安裝第一塊板的支撐點。

- 預先根據接縫和顏色鋪開4至5排各類木板。
- 從起點向外，用鏡刀以45°角塗抹粘劑。
- 沿著起始線安裝第一塊木板，使榫舌面向您，凹槽面向起始牆。始終在行末端保留 19 毫米 (0.75 英寸) 的膨脹間隙。
- 分小部分進行，以便在安裝之前粘劑不會干燥。
- 按照從左到右的順序安裝該行中的其他板。
- 最後一排板必須被切割。廢料部分可用于開始下一行。
- 對於接下來的行，將榫舌插入凹槽並將板降低到相鄰板中，並避免接觸粘劑。可能需要使用錘塊將舌部打入凹槽中。
- 在每 5 或 6 排上粘貼適用於木地板的膠帶，以確保木板牢固固定到位。

- 注意：在寬/長木板安裝中，必須在每塊木板的長度和末端添加支撐帶。支撐帶周圍並使用緊固帶和重物，直到脫水固化。
- 在粘劑仍處於活性狀態時，使用 45.4 至 68 克 (100 至 150 磅) 滾筒對安裝部分施加壓力 (約 45 至 60 分鐘)。對整個地板重復這些步驟。
- 為獲得最佳效果，請將端接點與前一行錯開 145 毫米至 290 毫米 (5.71 英寸至 11.42 英寸)，並交替板的長度。

- 表面完全覆蓋後，拆下直邊並將板放置在安裝開始時留下的 158 毫米 (6.22 英寸) 空間內。

重要提示：安裝過程中，立即擦掉地板表面的任何粘劑。

#### 完工後保護您的地板:

- 維護地板時使用非磨料材料非常重要，以保護它們免受其他行業的影響。請勿放置重物，因為它可能會因壓力點而損壞地板。請勿直接在地板表面使用任何粘劑或膠帶，因為這可能會造成損壞。溫度和濕度含量應保持如下：溫度為 19° C 至 20° C，濕度為 40% 至 60%。請保護已安裝的地板，直到現場所有工作完成為止，以避免損壞，特別是在手刮、錘擊和橫切節面上，因為污垢可能殘留在顆粒上，然後很難清除。

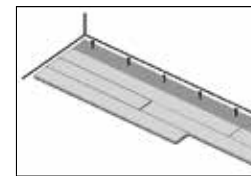
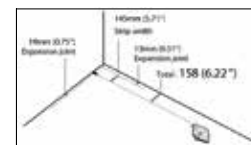

# MAINTENANCE INSTRUCTIONS

INSTRUCCIONES DE MANTENIMIENTO / ISTRUZIONI DI MANUTENZIONE / 维护说明

**LOCKSTEP**  
EXCELLENT GLUELESS SYSTEM

Patent-protected  
worldwide

## SIMPLE TIPS TO AVOID DAMAGE / CONSEJOS SIMPLS PARA EVITAR DAÑOS / SEMPLICI CONSIGLI PER EVITARE DANNI / 避免磨损的简单提示

- Don't clean wooden floors with a wet mop. Too much water can cause the floor to swell, warp or turn grey.
  - Don't use wax, soap or other household cleaners on wooden floors coated with finish. They can dull the floor's finish.
  - Don't let sand, dirt or grit build up. They can act like sandpaper: abrading and dulling your floor finish.
  - Vacuum or sweep your floors regularly. Once every week is recommended.
  - Remove spills promptly.
  - Place mats at exterior doors to trap sand and grit. Use rugs in high traffic pathways, at the ends of stairs and near doorways.
- Avoid rubber backing or non-ventilated rugs.
- Use protective pads or caps on furniture.
  - Trim your pet's claw. Proper claw trimming helps avoid scratches and gouges.

Just spray and clean

- No utilizar una fregona mojada para limpiar los suelos de madera. El exceso de agua puede provocar dilatación, deformación o la aparición de manchas grisáceas.
- No use cera, jabón u otros productos de limpieza en los suelos de madera lacados. Esto podría hacerlo mate.
- No permita que se acumule arena, suciedad o polvo. Estos podrían producir un efecto de papel de lija: produciendo abrasión y embotamiento en el acabado.
- Se recomienda aspirar o barrer los suelos con regularidad. Al menos una vez por semana.
- Limpie rápidamente la suciedad o los líquidos derramados en el suelo.
- Coloque felpudos en las puertas exteriores para evitar que entre arena o piedras. Use alfombras en las zonas de tráfico elevado, cerca de los extremos de las escaleras y las puertas. Evite las esteras o alfombras de goma o caucho sin ventilación.
- Use almohadillas protectoras para las patas los muebles.
- Corte las uñas de su animal de compañía. Unas uñas cortas ayudarán a evitar rayas y arañazos.

Simplemente rocíe y limpie

- Non pulire i pavimenti in legno con uno scopettone bagnato. Troppa acqua può far sì che il pavimento si dilati, si deformi o diventi grigio.
- Non utilizzare cera, saponi od altri prodotti casalinghi con pavimenti in legno ricoperti. Questi possono rovinare il rivestimento del legno.
- Non lasciare che si accumulino sabbia, sporco o polvere. Potrebbero avere un effetto "cartavetrata": abradendo e rovinando il rivestimento del pavimento.
- Passare l'aspirapolvere o la scopa regolarmente. Si raccomanda una volta alla settimana.
- Rimuovere eventuali gocce subito con lo scopettone.
- Collocare materassini isolanti ai piedi delle porte esterne per bloccare la polvere e la sabbia. Utilizzare zerbini nelle zone ad alto traffico, in fondo a sale e vicino alle soglie. Evitare supporti in gomma o zerbini non ventilati.
- Usare tappini protettivi o cappucci nei mobili.
- Tagliare puntualmente gli artigli ai vostri animali domestici. Una adeguata igiene aiuta ad evitare graffi e segni sul pavimento.

Polverizzate uno spray e pulite

- 不要用湿拖把把清洁木地板。过多的水会使地板膨胀，翘曲或变灰。
- 不要用蜡、肥皂或其他家用清洁剂在木质地板上涂上漆面。他们会把地板的漆面漆暗。
- 不要让沙子、灰尘或沙子堆积起来。他们可以像砂纸：研磨和削弱你的地板装修。
- 定期打扫或对地板吸尘。建议每周一次。
- 及时清除打翻的水渍。
- 将垫子放在外部门上以隔绝沙子和砂砾。在交通频繁的路口使用地毯，在楼梯的末端和门口附近。避免使用橡胶背衬或不通风的地毯。
- 在家具角上使用保护垫。
- 修剪你的宠物的爪子，可以避免刮痕和抓痕。

进行喷雾和清洁

**1**



Remove dirt and grit.  
Elimine la suciedad y el polvo.  
Toglie lo sporco e la polvere.  
清除污垢和砂砾。

**2**



Spray with Bona Wood Floor Deep Cleaner.  
Rocíe el limpiasuelos de madera Bona.  
Pulire con il pulitore per legno Bona.  
喷上博纳木地板清洁剂。

**3**

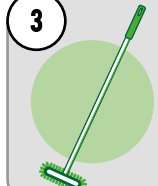

Wipe with a slightly damp Bona Cleaning Pad.  
Limpie con la mopa Bona ligeramente húmeda.  
Si pulisce semplicemente passando un panno umido.  
用稍微湿润的清洁垫擦拭。

### Bona Wood Floor Deep Cleaner

- Protection and care for your floor.
- Streak-free cleaning, without residues.
- Effectively removes stains, dirt and grime.
- Cleans without adding water. Water can damage wood.
- Ready to use. Just spray and mop. No mixing. No bucket.
- Non-toxic and environmentally sound.
- Especially made for wooden floors by the specialists.

### Limpiador para suelos de Madera Bona:

- Protección y cuidado para su suelo de madera.
- Limpieza antirrayas, sin dejar residuos.
- Elimina eficazmente las manchas y la suciedad.
- Limpia sin necesidad de agua. El agua puede dañar la madera.
- Listo para usar. Sólo pulverizar con el spray y limpiar. No hay que mezclar. No necesita cubo.
- No es tóxico y es respetuoso con el medioambiente.
- Especialmente hecho por especialistas para suelos de madera.

### Pulitore per pavimenti in legno Bona

- Protezione e cura del pavimento.
- Pulitura senza lasciare residui né striature.
- Rimuove efficacemente le macchie e lo sporco più ostinato.
- Non è necessario aggiungere acqua. L'acqua può danneggiare il legno.
- Facile da usare. Si deve solo polverizzare e pulire con lo scopettone. Non è necessario mescolare prodotti. No serve il secchio.
- Non produce inquinamento acustico o ambientale.
- Creato appositamente per il pavimento da specialisti.

### 博纳木地板清洁剂

- 保护和爱护你的地板。
- 无条纹清洁，无需过多费用。
- 有效地去除污渍和污垢。
- 清洁时不加水。水会损坏木头。
- 准备使用时就用喷雾和拖把。不可混合。清洁动作不可过于剧烈
- 无毒，环保
- 尤其是由专家们制作的木地板。



Available in a 1 litre spray bottle as a 4 litre refill. Use together with the Bona Cleaning Pad in microfibre.

Disponibile in spray de 1 litro, o en envase de 4 litros. Usar junto con la mopa Bona de microfibra.

Disponibile in confezioni da un litro e in ricambi da 4 litri. Da utilizzarsi insieme al panno in micro fibra Bona.

可在1升的喷雾瓶中作为4升的替换。使用微纤维的博纳清洁垫

# ENVIRONMENTAL CERTIFICATIONS

CERTIFICACIONES MEDIO AMBIENTALES / CERTIFICAZIONI AMBIENTALI / 证书



## CE

All pre-finished STP products have a CE certificate (ref. Law EN 14342:2006). The CE directive urged by the fact that all construction elements should be conceived and produced to guarantee the security of human beings, animals and objects allow the introduction on the European market only of those products created with the characteristics provided for by the CE regulation.

The most important characteristics of pre-finished parquet floorings are described by the CE-label, which is specified through DIN EN14342 in turn. In addition to the release of formaldehyde and pentachlorophenol, slipping performance, heat conductance, breaking resistance, and biological durability, the fire-related properties of wooden- and parquet floorings are classified too.

Todos los productos STP pre-acabados poseen el certificado (ref. Norma EN 14342:2006). La directiva comunitaria sobre el marcado CE, fue concebida para garantizar la seguridad de personas, cosas o animales, lo que permite la introducción en el mercado Europeo únicamente de los productos creados acorde a las características requeridas por regulación CE.

Las características más importantes de los productos de parquet poseedores del marcado CE, (DIN EN14342:2006) son: La emisión de formaldehído y el pentaclorofenol, la resistencia al deslizamiento, la conductividad de térmica, la resistencia a la rotura y la durabilidad biológica, así como las propiedades relativas a la reacción al fuego del parquet o de otros tipos de suelos de madera.

Tutti i prodotti STP sono certificati CE (rif. norma EN 14342:2006). La direttiva comunitaria sulla marcatura CE è stata concepita per garantire la sicurezza di persone, cose e animali, permettendo l'immissione sul mercato europeo unicamente di prodotti creati con le caratteristiche previste dalla legge.

Le caratteristiche principali dei prodotti da parquet che posseggono il marchio CE sono: L'emissione di Formaldeide, il pentaclorofenolo, resistenza allo scivolamento, Conduttività termica, Resistenza alla rottura, e la durabilità biologica, oltre alle proprietà relative alla reazione al fuoco del parquet o di altri tipi di pavimenti in legno.

所有STP产品都有CE证书(参考法律EN 14342:2006)。CE证书的要求是,所有建筑元素的构思和生产都应保证人类、动物和物体的安全,因此只允许将符合CE法规所规定的特性的产品引入欧洲市场。

预加工的地板的最重要特征通过ce标签进行描述,该标签依次通过DIN EN14342进行规定。除了释放甲醛和五氯酚、防滑性能、热导性、抗断裂性和生物耐久性外,木地板的防火性能也进行了分类。



The mark of responsible forestry

## FSC

FSC® CERTIFICATE, which identifies the products containing wood originated from forests that are managed in a correct and responsible way according to rigorous environmental, social, and economical standards.

The originating forest is controlled and evaluated independently according to these standards (principles and rules for a good forest management) which are established and approved by the Forest Stewardship Council a.c. with the participation and the consent of the involved parties. FSC under request.

CERTIFICACIÓN FSC®, identifica los productos que contienen madera de bosques de tala controlada de manera correcta y responsable de acuerdo con rigurosos estándares ambiental, social y económico.

El bosque en su origen es controlado y evaluado de forma independiente de acuerdo con estos estándares (principios y criterios de buena gestión forestal), establecidos y aprobados por el Forest Stewardship Council a.c. a través de la participación y el consentimiento de las partes interesadas. FSC bajo pedido.

CERTIFICAZIONE FSC®, che identifica i prodotti contenenti legno proveniente da foreste gestite in maniera corretta e responsabile secondo rigorosi standard ambientali, sociali ed economici.

La foresta di origine è controllata e valutata in maniera indipendente in conformità a questi standard (principi e criteri di buona gestione forestale), stabiliti ed approvati da Forest Stewardship Council a.c. tramite la partecipazione e il consenso delle parti interessate. FSC su ordinazione.

FSC®证书,该证书识别了根据严格的环境、社会和经济标准以正确和负责任的方式管理来自森林的木材产品。原始森林是根据这些标准(良好森林管理的原则和规则)进行独立控制和评价的,这些标准由森林管理委员会在有关各方的参与和同意下制定和核准。

## FORMALDEHYDE EXEMPT

In full respect of the class E1 limits of the norm UNI EN 717-2:95, as emerging from the analysis conducted by AIDIMA, an accredited laboratory for analysis testing.

En concordancia con los límites establecidos por la norma UNI EN 717-2:95 Clase E1, tal y como se muestra en el estudio realizado por AIDIMA, laboratorio acreditado para estas pruebas de análisis.

Pieno rispetto dei limiti per la classe E1 della norma UNI EN 717-2:95, come emerge dalle analisi condotte dal AIDIMA, laboratorio accreditato per prove di analisi.

完全遵守规范UNI EN 717-2:95的E1级,由AIDIMA(分析测试的认可实验室)进行的分析得出。

## FIREPROOF CERTIFICATION

In full respect of the class Cf-s1 limits of the norm EN 13501, as emerging from the analysis conducted by AIDIMA, an accredited laboratory for analysis testing.

En concordancia con los límites establecidos por la norma EN 13501 Classe Cf-s1, tal y como se muestra en el estudio realizado por AIDIMA, laboratorio acreditado para estas pruebas de análisis.

Pieno rispetto dei limiti per la classe Cf-s1 della norma EN 13501, come emerge dalle analisi condotte dal AIDIMA, laboratorio accreditato per prove di analisi.

Cf1-s1, 严格遵守EN 13501的标准限值,由AIDIMA(分析测试的认可实验室)进行分析产生。

## ANTIBACTERIAL

For its wooden floorings, STP developed finishing varnishes with hygienic activity reducing the bacterial load to 99.99%.

The biocide action can result through the interaction with biological target structures, or through interferences in the cell metabolic and energetic processes; in other words, blocking the bacteria's breathing provoking its death as a consequence.

The wooden floors treated with these varnishes enable to have a first precaution in case there is a need to reduce bacterial contamination in a short time, especially when it might be very difficult to guarantee a deep cleansing due to the position of the base itself or in public environments where an immediate hygienic action may be necessary.

The treatment is particularly suitable for wooden floors in houses or environments with pets.

STP ha desarrollado para sus suelos de madera barnices con actividad higienizante, lo que logra reducir la carga bacteriana en un 99,99%.

La acción bactericida viene dada por la interacción con las estructuras biológicas o por medio de interferencias en el metabolismo celular y los procesos energéticos, es decir, bloquear la respiración de las bacterias provocando como consecuencia su muerte.

Los suelos de madera tratados con estos barnices permiten una primera prevención a corto plazo en caso de necesidad de reducción de la contaminación bacteriana, especialmente cuando sería verdaderamente difícil garantizar una profunda higiene debido a la colocación del propio suelo o en ambientes públicos en los que se requiera una inmediata acción de limpieza.

El tratamiento está especialmente indicado para los pavimentos de madera en casa o ambientes con animales domésticos.

STP ha sviluppato delle vernici di finitura con attività igienizzante per i propri pavimenti in legno, che riducono la carica batterica del 99,99%. L'azione biocida si dà per l'interazione con strutture bersaglio biologiche, oppure attraverso interferenze in processi metabolici ed energetici della cellula; in altre parole bloccando la respirazione del batterio e provocandone di conseguenza la morte.

I pavimenti in legno trattati con queste vernici forniscono una prima precauzione dove possa essere richiesta una riduzione della contaminazione batterica in tempi brevi, soprattutto dove può essere molto difficile garantire una pulizia profonda anche a causa della posizione del supporto stesso o in ambienti pubblici dove può essere utile garantire una azione igienizzante immediata.

Il trattamento risulta particolarmente adatto per pavimenti in legno posti in ambienti o abitazioni frequentati da animali domestici.

对于实木地板,STP开发了具有卫生活性的表面清漆工艺,可以将细菌载量降低99.99%。

生物杀灭作用可以通过与生物靶结构的相互作用,或通过干扰细胞的代谢和能量过程产生;换句话说,阻断细菌的呼吸从而导致其死亡。

木质地板处理通过专门的清漆工艺处理使先有一个预防措施,以防有需要在短时间内减少细菌污染,特别是当它可能很难保证深度清洗由于基地本身的位置或在公共环境中立即卫生行动可能是必要的。

这种处理方法特别适用于有宠物的房屋或环境中的木地板

## BIOLOGICAL DURABILITY

STP complies with the norm EN 335-1 & 2 Use Class 1. That reduces the risk of surface attack by mold or mushrooms. The blueness or ligniperduos mushrooms aren't a significant threat.

STP cumple con la norma EN 335-1 & 2 Clase de uso 1. Eso reduce el riesgo de que la superficie se vea dañada por el ataque de hongos o mohos. El florecimiento o los ligniperduos no constituyen una amenaza importante.

STP soddisfa la norma EN 335-1 & 2 Clase de uso 1. Ciò riduce il rischio che la superficie sia attaccata da muffa o funghi, l'umidità e ligniperduos non è una grave minaccia.

STP符合标准EN 335-1和2的Class 1。这意味着表面有可能会引起霉菌攻击的风险,但没有青色或对木质有害的蘑菇菌

## SOLVENT FREE

During the complementary manufacturing, in the lacquering and UV varnishing cycles, and during the use of adhesives, there is no emission of solvents in the atmosphere, harmful to human-beings and the environment.

Durante el proceso de fabricación complementaria, en los ciclos de lacado y barnizado UV y durante el uso de adhesivos, no existe ningún tipo de emisión a la atmósfera de disolventes perjudiciales para los seres humanos o para el medio ambiente.

Nelle lavorazioni complementari, nei cicli di verniciatura e oliatura UV e nell'utilizzo di collanti non vi è alcuna emissione di solventi in atmosfera, nocivi per l'uomo e l'ambiente.

在完整的生产过程中,在表面漆和UV漆循环过程中,在使用粘合剂的过程中,没有任何对人类和环境有害溶剂排放到大气中。



## VOC EMISSIONS

STP products fulfill the requirements established for Class A+ in the Decree No. 2011-321 of March 23, 2011 of the French Ministry of Ecology, Sustainable Development, Transport, and Housing.

Los productos STP cumplen los requisitos de la Clase A+ del decreto N° 2011-321 del 23 de marzo, 2011 del Ministerio Francés de Ecología, Desarrollo Sostenible, Transporte y Vivienda.

I prodotti STP soddisfano i requisiti stabiliti per la Classe A+ nel Decreto n. 2011-321 del 23 marzo, 2011 del Ministero Francese dell'Ecologia, dello Sviluppo Sostenibile, dei Trasporti e dell'Edilizia Abitativa.

STP产品完全符合2011-321号法令标准的A+等级,该法令是2011年3月23日颁布的。

**nwfa**  
National Wood  
Flooring Association  
MEMBER

















# TECHNICAL FEATURES

INFORMACION TECNICA / INFORMAZIONI TECNICHE / 技术特点

**WOOD<sup>+</sup>**  
MORE THAN WOOD

SIMB	FEATURES / CARACTERISTICAS CARATTERISTICHE / 产品特性	NORM / NORMA / NORMA / 产品标准	NORM VALUE VALORES NORMA VALORI NORMA 标准评估	STP VALUE / VALORES STP VALORI STP / 价值
	Level of use Clase de Uso Classe d'uso 使用等级	EN 685	-	Classic Traditional Lux  Traffic 
	Abrasion resistance Resistencia a la abrasión Resistenza all'abrasione 耐磨性	EN 14354 Anexo D	WR2 IP > 5000 WR3 IP > 7000	Classic/Traditional/Lux WR2IP=5000 Traffi c WR3 IP=9000
	Impact resistance Resistencia al impacto Resistenza all'impatto / 防撞性	EN 14354 Anexo C	EC2 > 1200 mm	EC2
	Formaldehyde emission Emisión Formaldehído Emissione Formaldeide / 甲醛释放	EN 717-2:95	E1	E1
	Biological durability Durabilidad biológica Durabilità biologica / 生物持久性	EN 355-1 y 2	-	Class 1
	Fire reaction Reacción al fuego Reazione al fuoco / 防火等级	EN 13501	-	Class C <sub>fl-s1</sub>
	Skid resistance Resistencia al deslizamiento Resistenza allo scivolamento 防滑性	EN 13893	-	Class DS
	Thermal conductivity Conductividad térmica Condutività termica / 导热系数	EN 12524	-	0,17 W/mk
	Breaking strength (maximum load) Resistencia a la rotura (carga máxima) Resistenza alla rottura (carico massimo) 断裂强度 (最大负荷)	-	-	PND
	CE certificate / Certificado CE Certificato CE / CE认证	EN 1432:2006	SI	SI
	Density / Densidad / Densità / 密度	-	-	706 (26) Kg/m <sup>3</sup>
	Dimensional stability / Estabilidad dimensional / Stabilità dimensionale / 稳定性	EN 1910	-	Paralelo - Parallelo - Paral. 0,13 mm Perpend - Perpendicolare - Perp. 0,66 mm
	Moisture content Contenido en humedad Contenuto umidità / 含水量	-	-	9,90 (0,74) %
	VOCs emission Emisión de VOC Emissione COV VOC排放量	ISO 16000-6:2006	A+ = < 1000 µg/m <sup>3</sup>	28 µg/m <sup>3</sup> 

<b>PRODUCT</b>	Two layers pavement
<b>SUPPORT</b>	9 alternating layers of 100% birch engineered plywood
<b>THICKNESS</b>	15/16 mm (depending on series and finish)
<b>INSTALATION</b>	Floating with no adhesive or glue down
<b>TECHNOLOGY</b>	LockSTP / T&G

<b>PRODOTTO</b>	Pavimento y revestimiento bicapa
<b>SOPORTE</b>	9 capas alternas de madera contrachapada 100% abedul mecanizadas
<b>ESPESOR</b>	15/16 mm (dependiendo de colección y acabado)
<b>INSTALACIÓN</b>	Flotante en seco o encolada
<b>TECNOLOGÍA</b>	LockSTP / T&G

<b>PRODOTTO</b>	Pavimento e rivestimento a due strati
<b>SUPPORTO</b>	9 strati alternati di multistrato 100% betulla
<b>SPESSORE</b>	15/16 mm (dipendendo della collezione e la finitura)
<b>INSTALLAZIONE</b>	Flottante senza colla o incollata
<b>TECNOLOGIA</b>	LockSTP / T&G

产品	两层保护层
支持	100%全桦木基材, 9层纵横交错结构
厚度	15或者16毫米 (取决于不同系列和表面处理工艺)
安装	无胶悬浮安装和传统胶水安装
技术支持	LockSTP 全球专利锁扣安装系统/ T&G传统安装系统

# PACKING

PACKING LIST / 打包清单

FORMAT	SQM/ PC	SQM/ BOX	PC/ BOX	WEIGHT/ BOX. (KG)	PC/ PAL.	BOX/ PAL.	SQM/ PAL.	MES./PALLETS	F/C	~WEIGHT/ PAL. (KG)	
<b>WOOD+</b>											
<b>290x290<sup>3</sup></b>	0,0841	1,6820	20	19	520	26	43,732	1220x0620x1130	F13C2	512	
<b>580x290</b>	0,1682	1,6820	10	19	260	26	43,732	1220x0620x1130	F13C2	512	
<b>580x580<sup>4</sup></b>	0,3364	1,6820	5	19	130	26	43,732	1220x0620x1130	F13C2	512	
<b>870x290</b>	0,2523	2,0184	8	22	224	28	56,515	1220x0900x1050	F14C2	650	
<b>870x870</b>	0,7569	1,5138	2	17	50	28	37,845	0910x0910x1150	F28C1	445	
<b>1160x290<sup>1</sup></b>	0,3364	2,0184	6	23	108	18	36,331	1220x0620x1000	F18C1	431	
<b>1160x580<sup>2</sup></b>	0,6728	2,0184	3	23	54	18	36,331	1220x0620x1000	F18C1	431	
<b>1160x1160<sup>4</sup></b>	1,3456	1,3456	1	15	50	50	67,280	1185x1185x1030	F50C1	787	
<b>Tavole STP (T&amp;G)</b>											
<b>Herringbone</b>	<b>580x100</b>	0,0580	1,7400	30	20	780	26	45,240	1220x0620x1130	F13C2	538
<b>1160x155</b>		0,1798	2,1576	12	24	240	20	43,152	1220x0640x1050	F20C1	511
<b>1450x155</b>		0,2248	1,3488	6	15	252	42	56,650	1490x1000x0770	F7C6	656
<b>1450x180</b>		0,2610	1,3050	5	15	200	40	52,200	1490x1090x0760	F8C5	626
<b>1450x205</b>		0,2973	1,4865	5	17	200	40	59,460	1490x1090x0760	F8C5	706
<b>1740x155</b>		0,2697	1,6182	6	18	252	42	67,964	1790x1000x0770	F7C6	782
<b>1740x180</b>		0,3132	1,5660	5	18	200	40	62,640	1790x1090x0760	F8C5	752
<b>1740x205</b>		0,3567	1,7835	5	20	200	40	71,340	1790x1090x0760	F8C5	832
<b>1740x230</b>		0,4002	1,2006	3	14	156	52	62,431	1790x1000x0770	F13C4	774
<b>2030x155</b>		0,3147	1,8882	6	21	252	42	79,304	2080x1040x0770	F7C6	927
<b>2030x180</b>		0,3654	1,8270	5	21	200	40	73,080	2080x1090x0760	F8C5	869
<b>2030x205</b>		0,4162	2,0810	5	23	200	40	83,240	2080x1090x0760	F8C5	949
<b>2030x230</b>		0,4669	1,4007	3	16	156	52	72,836	2080x1000x0770	F13C4	902
<b>2320x155</b>		0,3596	2,1576	6	25	252	42	90,619	2360x1000x0770	F7C6	1088
<b>2320x180</b>		0,4176	2,0880	5	23	200	40	83,520	2360x1090x0760	F8C5	958
<b>2320x205</b>		0,4756	2,3780	5	26	200	40	95,120	2360x1090x0760	F8C5	1078
<b>2320x230</b>		0,5336	1,6008	3	18	156	52	83,242	2360x1000x0770	F13C4	1004
<b>2900x230</b>		0,6670	2,0010	3	21	156	52	104,052	2950x1000x0770	F13C4	1166
<b>LISTONE (LockSTP)</b>											
<b>580x145</b>	0,0841	1,6820	20	19	520	26	43,732	1220x0620x1130	F13C2	512	

100% Made in Spain

FORMAT	SQM/ PC	SQM/ BOX	PC/ BOX	WEIGHT/ BOX. (KG)	PC/ PAL.	BOX/ PAL.	SQM/ PAL.	MES./PALLETS	F/C	~WEIGHT/ PAL. (KG)	
<b>870x145</b>	0,1262	2,0192	16	23	448	28	56,538	1220x0900x1050	F14C2	689	
<b>1160x145</b>	0,1682	2,0184	12	22	216	18	36,331	1220x0620x1000	F18C1	427	
<b>1450x145</b>	0,2103	1,2618	6	15	252	42	52,996	1490x1000x0770	F7C6	656	
<b>1450x175</b>	0,2538	1,2690	5	15	200	40	50,760	1490x1090x0760	F8C5	626	
<b>1450x195</b>	0,2828	1,4140	5	17	200	40	56,560	1490x1090x0760	F8C5	706	
<b>1740x145</b>	0,2523	1,5138	6	17	252	42	63,580	1790x1000x0770	F7C6	740	
<b>1740x175</b>	0,3045	1,5225	5	17	200	40	60,900	1790x1090x0760	F8C5	712	
<b>1740x195</b>	0,3393	1,6965	5	19	200	40	67,860	1790x1090x0760	F8C5	792	
<b>1740x230</b>	0,4002	1,2006	3	14	156	52	62,431	1790x1000x0770	F13C4	774	
<b>2030x145</b>	0,2944	1,7664	6	19	252	42	74,189	2080x1040x0770	F7C6	843	
<b>2030x175</b>	0,3553	1,7765	5	20	200	40	71,060	2080x1090x0760	F8C5	829	
<b>2030x195</b>	0,3959	1,9795	5	22	200	40	79,180	2080x1090x0760	F8C5	909	
<b>2030x230</b>	0,4669	1,4007	3	16	156	52	72,836	2080x1000x0770	F13C4	902	
<b>2320x145</b>	0,3364	2,0184	6	23	252	42	84,773	2360x1000x0770	F7C6	1004	
<b>2320x175</b>	0,4060	2,0300	5	23	200	40	81,200	2360x1090x0760	F8C5	949	
<b>2320x195</b>	0,4524	2,2620	5	25	200	40	90,480	2360x1090x0760	F8C5	1038	
<b>2320x230</b>	0,5336	1,6008	3	18	156	52	83,242	2360x1000x0770	F13C4	1004	
<b>2900x230</b>	0,6670	2,0010	3	21	156	52	104,052	2950x1000x0770	F13C4	1166	
<b>CHEVRON</b>											
<b>410x145</b>	0,0595	1,1900	20	13	520	26	30,940	1220x0620x1130	F13C2	369	
<b>580x145</b>	0,0841	1,1774	14	14	420	30	35,322	1050x0910x1100	F6C5	442	
<b>870x145</b>	0,1262	1,7668	14	20	420	24	42,403	1105x0910x1100	F6C4	509	
<b>580x205</b>	0,1189	1,1890	10	14	300	30	35,670	1050x0910x1100	F6C5	442	
<b>870x205</b>	0,1784	1,7840	10	20	240	24	42,816	1105x0910x1100	F6C4	509	
<b>W+DESIGN</b>											
<b>Braid</b>	<b>580x145 A</b>	0,0736	1,5770	5	18	130	26	41,002	1220x0620x1130	F13C2	629
	<b>580x145 B</b>	0,0736		5		130					
	<b>615x410 C</b>	0,1682		5		130					

FORMAT		SQM/ PC	SQM/ BOX	PC/ BOX	WEIGHT/ BOX. (KG)	PC/ PAL.	BOX/ PAL.	SQM/ PAL.	MES./PALLETS	F/C	~WEIGHT/ PAL. (KG)
<b>Diamond</b>	<b>502x290</b>	0,0728	1,0920	15	13	390	26	28,392	1220x0620x1130	F13C2	346
<b>Herring. Chain</b>	<b>580x145</b>	0,0725	1,4500	20	15	520	26	37,700	1220x0620x1130	F13C2	408
<b>Herring. Chain</b>	<b>870x145</b>	0,1145	1,8320	16	19	448	28	51,296	1220x0900x1050	F14C2	559
<b>Hexagon</b>	<b>290x251</b>	0,0546	1,0920	20	12	520	26	28,392	1220x0620x1130	F13C2	330
<b>Hexagon</b>	<b>580x502</b>	0,2185	1,0925	5	13	130	26	28,405	1220x0620x1130	F13C2	354
<b>Link 580</b>	<b>525x341 A</b>	0,0989	1,1723	7	14	182	26	30,480	1220x0620x1130	F13C2	382
	<b>380x552 B</b>	0,1600		3		78					
<b>Looping 1-4</b>	<b>2030x205</b>	-	1,4424	4	16	200	50	72,120	2080x1090x0790	F10C5	858
<b>Looping 5-8</b>	<b>2030x205</b>	-	1,4200	4	16	200	50	71,000	2080x1090x0790	F10C5	858
<b>Looping 1-4</b>	<b>2030x230</b>	-	1,5336	4	17	160	40	61,344	2080x1000x0790	F10C4	737
<b>Looping 5-8</b>	<b>2030x230</b>	-	1,5140	4	17	160	40	60,560	2080x1000x0790	F10C4	737
<b>Morisco</b>	<b>290x290</b>	0,0467	0,9340	20	11	520	26	24,284	1220x0620x1130	F13C2	307
<b>Shuriken</b>	<b>290x290</b>	0,0539	1,0780	20	12	520	26	28,028	1220x0620x1130	F13C2	330
<b>Silhouette</b>	<b>580x429</b>	0,1844	0,9220	5	11	130	26	23,972	1220x0620x1130	F13C2	304
<b>Squama</b>	<b>290x290</b>	0,0471	1,1775	25	14	650	26	30,615	1220x0620x1130	F13C2	382
<b>Trapezium</b>	<b>580x145</b>	0,0631	1,2620	20	14	520	26	32,812	1220x0620x1130	F13C2	395
<b>Trapezium</b>	<b>870x145</b>	0,1051	1,6816	16	20	448	28	47,085	1220x0900x1050	F14C2	586
<b>Triangle</b>	<b>580x580</b>	0,1682	1,6820	10	19	260	26	43,732	1220x0620x1130	F13C2	512

<sup>1</sup>For **Rhombus** pattern, please, consider the same packing as Wood+ 1160x290 mm; <sup>2</sup>for **Trencadis** the same as Wood+ 1160x580 mm; <sup>3</sup>for **Dados** or **Mosaic**, the same as Wood+ 290x290 mm; <sup>4</sup>for any **Palace** pattern the same as Wood+ 580x580 mm or 1160x1160 mm in its case.

# TECHNICAL FEATURES

INFORMACION TECNICA / INFORMAZIONI TECNIQUE / 技术特点

**FiorWood**  
SLIM 3 LAYER TECHNOLOGY

SIMB	FEATURES / CARACTERISTICAS CARATTERISTICHE / 产品特性	NORM / NORMA / NORMA / 产品标准	NORM VALUE VALORES NORMA VALORI NORMA 准评估	STP VALUE / VALORES STP VALORI STP / 价值
	Level of use Clase de Uso Classe d'uso 使用等级	EN 685	-	Domestic - 23  Commercial - 32 
	Abrasion resistance Resistencia a la abrasión Resistenza all'abrasione 耐磨性	EN 14354 Anexo D	≥ 4000 revolutions	5000 revolutions
	Impact resistance Resistencia al impacto Resistenza all'impatto / 防撞性	EN 14354 Anexo C	EC2 > 1200 mm	EC2
	Formaldehyde emission Emisión Formaldehído Emissione Formaldeide / 甲醛释放	EN 717-2:95	E1	E1
	Biological durability Durabilidad biológica Durabilità biologica / 生物持久性	EN 355-1 y 2	-	Class 1
	Fire reaction Reacción al fuego Reazione al fuoco / 防火等级	EN 13501	-	Class C <sub>fl-s1</sub>
	Skid resistance Resistencia al deslizamiento Resistenza allo scivolamento 防滑性	EN 13893	-	Class DS
	Thermal conductivity Conductividad térmica Conduktività termica / 导热系数	EN 12524	-	0,17 W/mk
	Breaking strength (maximum load) Resistencia a la rotura (carga máxima) Resistenza alla rottura (carico massimo) 断裂强度 (最大负荷)	-	-	PND
	CE certificate / Certificado CE Certificato CE / CE认证	EN 1432:2006	SI	SI
	Density / Densidad / Densità / 密度	-	-	706 (26) Kg/m <sup>3</sup>
	Dimensional stability / Estabilidad dimensional / Stabilità dimensionale / 稳定性	EN 1910	-	Paralelo - Parallelo - Paral. 0,13 mm Perpend - Perpendicolare - Perp. 0,66 mm
	Moisture content Contenido en humedad Contenuto umidità / 含水量	-	-	9,90 (0,74) %
	VOCs emission Emisión de VOC Emissione COV VOC排放量	ISO 16000-6:2006	A+ = < 1000 µg/m <sup>3</sup>	28 µg/m <sup>3</sup> 

<b>PRODUCT</b>	Three layers pavement
<b>SUPPORT</b>	7 alternating layers of 100% birch engineered plywood
<b>THICKNESS</b>	10 mm (0,6+9+0,6)
<b>INSTALATION</b>	Floating with no adhesive or glue down
<b>TECHNOLOGY</b>	LockSTP / T&G

<b>PRODOTTO</b>	Pavimento y revestimiento tricapa
<b>SOPORTE</b>	7 capas de madera contrachapada 100% abedul mecanizadas
<b>ESPESOR</b>	10 mm (0,6+9+0,6)
<b>INSTALACIÓN</b>	Flotante en seco o encolada
<b>TECNOLOGÍA</b>	LockSTP / T&G

<b>PRODOTTO</b>	Pavimento e rivestimento a tre strati
<b>SUPPORTO</b>	7 strati alternati di multistrato 100% betulla
<b>SPESSORE</b>	10 mm (0,6+9+0,6)
<b>INSTALLAZIONE</b>	Flottante senza colla o incollata
<b>TECNOLOGIA</b>	LockSTP / T&G

<b>产品</b>	三层路面
<b>支持</b>	7 层交替的 100% 桦木工程胶合板
<b>厚度</b>	10毫米 (0,6+9+0,6)
<b>安装</b>	无胶悬浮安装和传统胶水安装
<b>技术支持</b>	LockSTP 全球专利锁扣安装系统/ T&G传统安装系统

SIMB	FEATURES / CARACTERISTICAS CARATTERISTICHE / 产品特性	NORM / NORMA / NORMA / 产品标准	NORM VALUE VALORES NORMA VALORI NORMA 标准评估	STP VALUE / VALORES STP VALORI STP / 价值
	Level of use Clase de Uso Classe d'uso 使用等级	EN 685	-	Domestic - 23  Commercial - 32 
	Abrasion resistance Resistencia a la abrasión Resistenza all'abrasione / 耐磨性	EN 14354 Anexo D	≥ 4000 revolutions	5000 revolutions
	Impact resistance Resistencia al impacto Resistenza all'impatto / 防撞性	EN 14354 Anexo C	EC2 > 1200 mm	EC2
	Formaldehyde emission Emisión Formaldehído Emissione Formaldeide / 甲醛释放	EN 717-2:95	E1	E1 (< 3.5 mg/m³h)
	Biological durability / Durabilidad biológica Durabilità biologica / 生物持久性	EN335-1 / EN335-2	-	PURE WOOD
	Fire reaction Reacción al fuego Reazione al fuoco / 防火等级	EN 13501	-	Class B <sub>fl-s1</sub>
	Skid resistance Resistencia al deslizamiento Resistenza allo scivolamento / 防滑性	EN 13893	-	Class DS
	Thermal conductivity Conductividad térmica Conduktività termica / 导热系数	EN 12524	-	0,17 W/mk
	CE certificate / Certificado CE Certificato CE / CE认证	EN 1432	-	EN1432:2006 + A1
	Density / Densidad / Densità / 密度	EN323	-	900 Kg/m³
	Weight / sqm / Peso / m² Peso / mq / 重量/平方米	-	-	8,5 kg/m²
	Thickness of the top layer Espesor de la capa superior Spessore dello strato superiore / 顶层厚度	EN14354	-	0,6 mm
	Deviation of thickness / Desviación del espesor Deviazione dello spessore / 厚度偏差	EN14354	-	≤ 0,5 mm
	Flatness deviation / Desviación planimetría Deviazione di planarità / 平整度偏差	EN324-2	-	1,5 mm/m
	Internal bond / Cohesión interna Legame interno / 内部结合	EN319	-	> 1,5 N/mm²
	Thickness distention / Distensión del espesor Distensione dello spessore / 厚度膨胀	EN317	< 18%	< 12%
	Moisture content / Contenido en humedad Contenuto umidità / 含水量	EN322	4% - 11%	6%
	Gloss / Brillo / Luminosità / 光泽度	-	-	15%
	Castor chair resistance Resistencia a la rueda de la silla Effetto di una sedia a rotelle / 脚轮椅阻力	EN425	-	No visible change
	Burning cigarette Resistencia a quemadura de cigarrillo Resistenza alle sigarette / 燃烧的香烟	EN438-2/2005	-	Class 3
	Underfloor heating/cooling / Calefacción por suelo radiante/refrigeración / Riscaldamento a pavimento/raffrescamento / 地暖/制冷	-	-	Ok
	Antistatic performance Rendimiento antiestático Rendimento antistatico / 抗静电性能	EN1815	< 2 Kv	< 2 Kv

<b>PRODUCT</b>	Three layers pavement
<b>SUPPORT</b>	HDF-E1 Waterproof
<b>THICKNESS</b>	10 mm (0,6+9+0,6)
<b>INSTALLATION</b>	Floating with no adhesive or glue down
<b>TECHNOLOGY</b>	LockSTP / T&G

<b>PRODOTTO</b>	Pavimento y revestimiento tricapa
<b>SOPORTE</b>	HDF-E1 Hidrófugo
<b>ESPESOR</b>	10 mm (0,6+9+0,6)
<b>INSTALACIÓN</b>	Flotante en seco o encolada
<b>TECNOLOGÍA</b>	LockSTP / T&G

<b>PRODOTTO</b>	Pavimento e rivestimento a tre strati
<b>SUPPORTO</b>	HDF-E1 Idrofugo
<b>SPESSORE</b>	10 mm (0,6+9+0,6)
<b>INSTALLAZIONE</b>	Flottante senza colla o incollata
<b>TECNOLOGIA</b>	LockSTP / T&G

<b>产品</b>	三层路面
<b>支持</b>	HDF-E1防水
<b>厚度</b>	10毫米 (0,6+9+0,6)
<b>安装</b>	无胶悬浮安装和传统胶水安装
<b>技术支持</b>	LockSTP 全球专利锁扣安装系统/ T&G传统安装系统

# PACKING

PACKING LIST / 打包清单



100% Made in Spain

FORMAT		SQM/PC	SQM/BOX	PC/BOX	WEIGHT/BOX (KG.)		PC/PAL.	BOX/PAL.	SQM/PAL.	MES/PALLETS	F/C	~WEIGHT/PAL. (KG.)	
<b>Fior<sup>+</sup> / Wpk<sup>+</sup></b>													
290x290		0,0841	2,3548	28	17	20	728	26	61,2248	1220x0620x1130	F13C2	460	555
580x290		0,1682	2,3548	14	17	20	364	26	61,2248	1220x0620x1130	F13C2	460	555
580x580		0,3364	2,3548	7	17	20	182	26	61,2248	1220x0620x1130	F13C2	460	555
870x290		0,2523	3,0276	12	22	25	336	28	84,7728	1220x0900x1050	F14C2	640	740
1160x290*		0,3364	3,3640	10	31	28	170	18	57,1880	1220x0620x1000	F18C1	430	540
1160x580*		0,6728	3,3640	5	31	28	85	18	57,1880	1220x0620x1000	F18C1	430	540
<b>FiorTavole<sup>®</sup> / WpkTavole<sup>®</sup></b>													
Herringbone	580x100	0,0580	2,4360	42	18	21	1092	26	63,3360	1220x0620x1130	F13C2	486	581
580x145		0,0841	2,3548	28	17	20	728	26	61,2248	1220x0620x1130	F13C2	460	555
870x145		0,1262	3,0288	24	22	25	672	28	84,8064	1220x0900x1050	F14C2	640	740
1160x145		0,1682	3,3640	20	31	28	340	18	57,1880	1220x0620x1000	F18C1	435	540
1160x195		0,2262	3,3930	15	31	28	255	17	57,6810	1200x0640x1130	F17C1	430	540
2320x145		0,3364	3,0276	9	22	25	450	50	151,3800	2360x1000x0770	F10C5	1145	1380
2320x195		0,4524	3,6192	8	26	30	320	40	144,7680	2360x1090x0750	F8C5	1095	1580
2320x230		0,5336	2,6680	5	19	24	240	48	128,0640	2360x0990x0750	F12C4	980	1212
<b>FiorChevron<sup>®</sup> / WpkChevron<sup>®</sup></b>													
410x145		0,0595	1,6660	28	12	15	728	26	43,3160	1220x0620x1130	F13C2	330	400
580x145		0,0841	1,8502	22	13	16	660	30	55,5060	1050x0910x1100	F6C5	430	530
580x205		0,1189	1,9024	16	14	15	480	30	57,0720	1105x0910x1100	F6C5	430	520
870x145		0,1262	2,7764	22	20	25	528	24	66,6336	1105x0910x1100	F6C4	503	623
870x205		0,1784	2,8544	16	21	26	384	24	68,5056	1105x0910x1100	F6C4	527	647
<b>Fior DESIGN<sup>®</sup> / Wpk DESIGN<sup>®</sup></b>													
Braid	580x145 A	0,0736	0,5152	7	15	19	182	26	57,4028	1200x0620x1130	F13C2	430	500
	580x145 B	0,0736	0,5152	7			182						
	615x410 C	0,1682	1,1774	7			182						

FORMAT		SQM/PC	SQM/BOX	PC/BOX	WEIGHT/BOX (KG.)		PC/PAL.	BOX/PAL.	SQM/PAL.	MES/PALLETS	F/C	~WEIGHT/PAL. (KG.)	
<b>Diamond</b>	<b>502x290</b>	0,0728	1,5288	21	11	13	546	26	39,7488	1220x0620x1130	F13C2	300	380
<b>Herring. Chain</b>	<b>580x145</b>	0,0725	2,0300	28	15	17	728	26	52,7800	1220x0620x1130	F13C2	408	460
<b>Herring. Chain</b>	<b>870x145</b>	0,1145	2,7480	24	20	23	672	28	76,9440	1220x0900x1050	F14C2	584	668
<b>Hexagon</b>	<b>290x251</b>	0,0546	1,5288	28	14	15	392	26	39,7488	1220x0620x1130	F13C2	380	390
<b>Hexagon</b>	<b>580x502</b>	0,2185	1,5295	7	11	13	182	26	39,7670	1200x0610x1120	F13C2	300	380
<b>Link 580</b>	<b>525x341 A</b>	0,0989	1,6901	9	12	14	234	26	43,9426	1220x0620x1130	F13C2	335	392
	<b>380x552 B</b>	0,1600		5			130						
<b>Looping 1-4</b>	<b>2320x230</b>	-	1,7532	4	13	16	224	56	98,1792	2360x1000x0780	F14C4	788	956
<b>Looping 5-8</b>	<b>2320x230</b>	-	1,7264	4	13	16	224	56	96,6784	2360x1000x0780	F14C4	788	956
<b>Morisco</b>	<b>290x290</b>	0,0467	1,3076	28	9	11	728	26	33,9976	1220x0620x1130	F13C2	255	310
<b>Shuriken</b>	<b>290x290</b>	0,0539	1,5092	28	11	13	728	26	39,2392	1220x0620x1130	F13C2	300	356
<b>Silhouette</b>	<b>580x429</b>	0,1844	1,2908	7	9	11	182	26	36,5608	1220x0620x1130	F13C2	252	304

<b>Squama</b>	<b>290x290</b>	0,0471	1,6485	35	11	14	910	26	42,8610	1220x0620x1130	F13C2	320	380
<b>Trapezium</b>	<b>580x145</b>	0,0631	1,7668	28	12	15	728	26	45,9368	1220x0620x1130	F13C2	330	410
<b>Trapezium</b>	<b>870x145</b>	0,1051	2,5224	24	18	21	672	28	70,6272	1220x0900x1050	F14C2	520	595
<b>Triangle</b>	<b>580x580</b>	0,1682	2,3548	14	17	20	364	26	61,2248	1220x0620x1130	F13C2	460	555
													
<b>Trencadis 16</b>	<b>1160x580</b>	0,6728	2,0184	3	18	28	51	17	34,3120	1220x0620x1000	F17C1	470	540
<b>Versailles 16</b>	<b>580x580</b>	0,3364	1,6820	5	17	20	130	26	43,7320	1230x0620x1150	F13C2	455	555

\*For FiorRhombus / WpkRhombus pattern, please, consider the same packing as Fior+ / Wpk+ 1160x290 mm; and for FiorTrencadis 10 / WpkTrencadis 10 the same as Fior+ / Wpk+ 1160x580 mm.







**STP**  
**Wood+ Flooring Industries**  
**Central Offices & Factory Plant.**  
C/ Olocau del Rei 3D (transversal CV-20. km 2,5)  
Apdo. correos / P.O. Box 211.  
12540 Vila-real / Castellón / Spain  
Tel. (34) 964 785 121  
[info@stp-woodflooring.com](mailto:info@stp-woodflooring.com)  
[www.stp-woodflooring.com](http://www.stp-woodflooring.com)

**eurolegno distribution inc.**  
**Canadian distribution & US agency**  
5333 Ferrier  
Montreal, Quebec  
Canada, H4P 1M1  
Tel: # 001 - 514 - 739 - 9416  
[info@eurolegnoluxuryfloors.com](mailto:info@eurolegnoluxuryfloors.com)

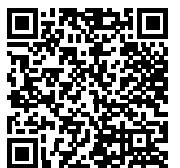



100% Made in Spain

